

Moving Details.

# Technical brochure Glass Partition Walls

Issue 2024

2024 Technical brochure Glass Partition Walls

211  
Marketing

**dg** DORMA  
GLAS®

New generation of  
locks and hinges  
as well as  
further product enhancements  
and  
-improvements !



### **Our Sustainability Commitment**

We are committed to foster a sustainable development along our entire value chain in line with our economic, environmental and social responsibilities toward current and future generations.

Sustainability at product level is an important, future-oriented approach in the field of construction. In order to give quantified disclosures of a product's environmental impacts through its entire life cycle, dormakaba provides Environmental Product Declarations (EPDs), in which the results of the life cycle assessment (LCA) are presented.



# Contents



**4** Trendsetting design

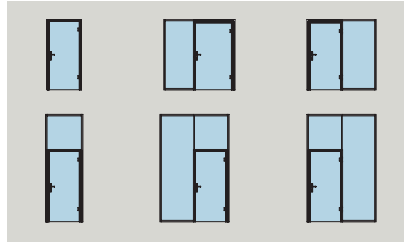

**10** Technical data



**26** Fixed glazing technology

**NEW**



**30** Single-action door technology



**44** Sliding door technology



**48** Acoustic module technology

**NEW**

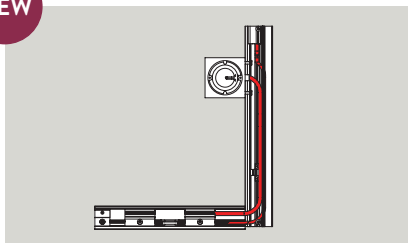

**50** Electrification

**NEW**



**52** Accessory technology

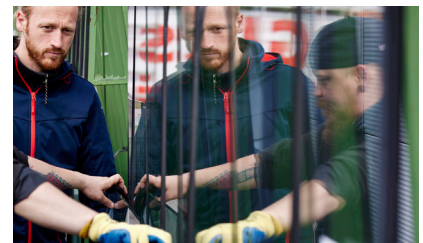

**58** Glass preparation

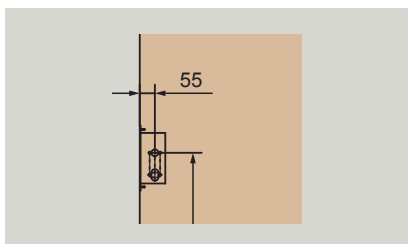

**62** Timber preparation

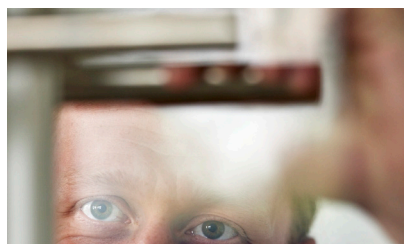

**64** Technical Support



**67** Safety-related information

# Trendsetting design

A profile system that impresses visually with its lightness and uniformity and at the same time is easy to plan and install.

This was the guiding principle behind the development of our versatile profile system with supplementary functional elements for the design of room entrances and independent room-within-a-room constructions. Thanks to decades of experience in the field of glass fitting technology and with a view to the future,

a system has been created that is convincing in terms of its appearance and function as well as its versatility and deconstructability. UNIQUIN. Visually and constructively convincing. As DORMA-Glas, we always maintain a close dialogue with architects, fabricators and

users, with their wishes being taken into account. In this way, product details are also adapted to market requirements over the course of time. So that our solutions are part of a contemporary and forwardlooking architecture.



## All elements as if from one cast

**With UNIQUIN you perfect the overall impression of your room layout.**

The German-made system offers you flush profiles, fittings and locking systems in a uniform design. The aluminum profiles as well as the visible functional elements receive a resistant surface by a powder coating, which can be selected in the color tone suitably the ambience. Typical for UNIQUIN

and particularly robust is the structural coating in anthracite gray. UNIQUIN accepts partition elements made of glass, but also wood or other materials in thicknesses from 10 to 19 millimeters.

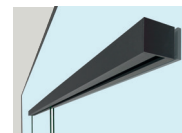

Sliding doors can also be effortlessly integrated



The desire for additional convenience on hinged doors is fulfilled by optional door closers (dormakaba TS 97 or TS 98).



In addition to anthracite grey (scratch-resistant), other subtle shades integrate well into contemporary architecture (see page 7). A variety of RAL colours is available on request.

NEW

## UNIQUIN 2.0 – The new generation of locks and hinges for our glass partition walls

**The UNIQUIN lock 2023 MultiVar – more freedom and flexibility in design and function**

- Changed lock housing: free choice of standard mortise locks according to DIN 18251
- Standard cut-outs for rosettes: Free choice of rosette lock inserts and lever handles for uniform equipment of entire projects
- Almost free choice of access control systems as long as they are designed for locks (e.g. dormakaba C-Lever Compact)
- Optional design variant for short plate: thus also possible for other access control systems
- New lock latches:
- Whisper latch as standard for quiet closing; magnetic latch lock optional.



Technical details can be found on page 30.

**The UNIQUIN hinges 2023 – conspicuously inconspicuous with simplified installation**

Hinges are screwed into the inside of the frames:

- Easy, fast installation
- Continuous frame cover profile, without interruption in the hinge area
- Cable routing possible within the entire frame, with connection option for switches or sockets also on the hinge side of the frame
- 180° door opening (not applicable when using door closers and drop-down seal)

**Hinges for light and heavy doors**

**UNIQUIN hinge 2023 Clamp&Cover 80**

- Very small hinge, completely inside the rebate, invisible from the outside of the frame
- Installation: clamping – without glass preparation!
- Up to 80 kg door weight

**UNIQUIN hinge 2023 standard 130**

- Size-reduced hinge, inconspicuously integrated into the system appearance
- Mounting: screw clamping on 2 glass holes
- Up to 130 kg door weight





# The system for communicative room designs



## UNIQUIN – The system for communicative room designs

Enhance your interior design. The system comprises partitions and door solutions that offer coordinated, attractive design coupled with impressive application

versatility. For effortlessly combined transparency and discretion: UNIQUIN.

01

### Sliding door

Create access points without losing space. With UNIQUIN you can incorporate single or double-leaf sliding doors with ease.

02

### Room-height single-action door

Incorporate door systems measuring up to 3 meters in height. These prestigious access points create a striking impression.

03

### Corners

Create rooms with continuous transparency and without vertical posts even in 90° – 180° room corners.

04

### Electrification

You can position switches, sockets or electronic connections at the door frame profiles. The cable supply is provided invisibly within the profiles.

05

### Acoustic module

The acoustic modules from UNIQUIN absorb sound waves from within to create a pleasant ambient feel. The fabric covering can be individually printed and backlit\*. Whether it's an eye-catching detail or discreet background – you decide.

06

### Sound protection

The decoupled mounting of your desired material in thicknesses between 10 to 19 mm reduces sound transmission. When using laminated safety glass with special sound protection films, the effect is even maximized: more transparency, less noise.

07

### Single-action door

Whether doors for selective visual privacy or homely accents, again, the choice is yours. With frames in a coordinated design for glass doors in 8 – 19 mm thickness and timber doors in 38 – 47 mm thickness.

08

### Door assemblies in structural openings

You can also use the same frame profiles from UNIQUIN for classic single-door solutions, giving a uniform, coordinated look throughout the entire building.

\* Concept and installation by others

## One system, many purposes



Transparent: Rooms created with UNIQUIN are bright and friendly.

Relaxation areas such as **lounges or break rooms** are given a new, communicative atmosphere with UNIQUIN: glass walls combined with attractive design from UNIQUIN create open and enticing spaces. Acoustically separated from the hustle

and bustle, they nevertheless remain integrated into the overall atmosphere. Here everyone can find the peace of mind they need to relax while staying close to the action.

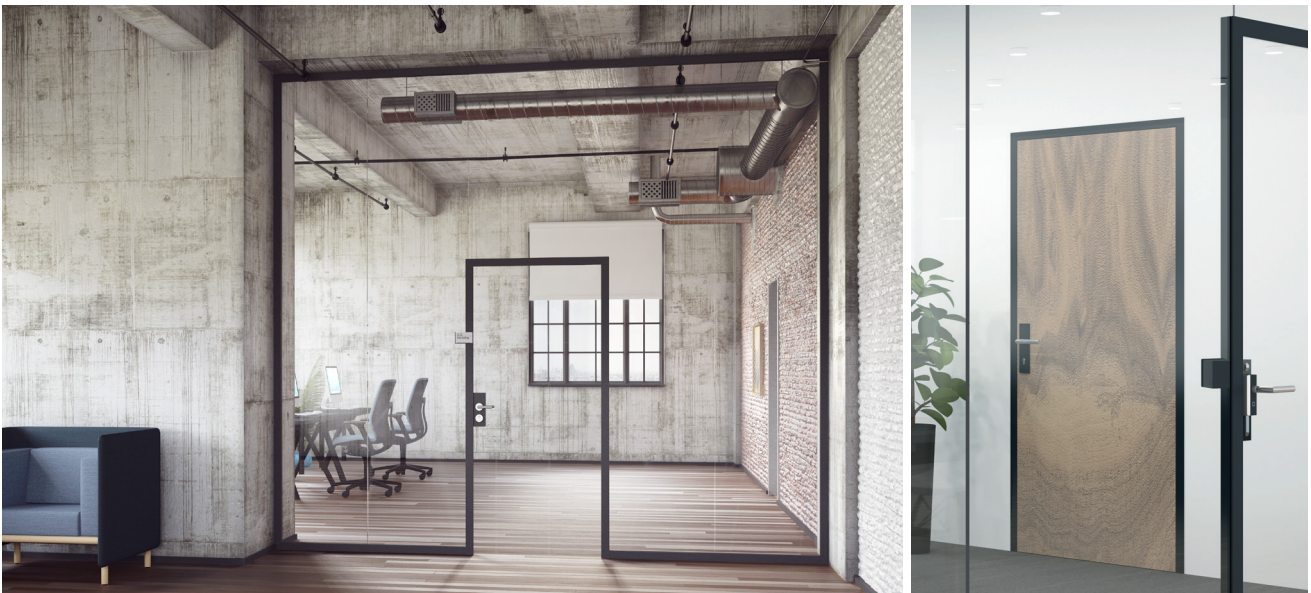

The UNIQUIN frame system is suitable both for rooms where full transparency is desirable and for individual door solutions. Variation is also possible: Timber, for example, can provide visual interest and discretion where it is required.

**Co-working spaces** should be focal points for focused and creative work, to which transparency need be no hindrance. Quite the contrary: an open, spacious interior, with incoming natural light and a wide panorama, creates a pleasant and motivating

atmosphere. This also helps in those decisive moments when thoughts need to be gathered and ideas allowed to mature. With UNIQUIN, offices benefit from reduced sound transmission, helping to promote productivity and creativity.



## Divides space without filling it



UNIQUIN offers particular benefits when it comes to efficiently harnessing space and natural light, for example in hotels. Harmonious: UNIQUIN profiles as well as the sliding door's track rail and pull handle offer a perfect match with the design concept, offering uniformity in both color and shape.

### Great in small spaces

UNIQUIN is the perfect choice wherever limited space needs to be utilized with maximum efficiency (home office, hotel room or hobby area). The system allows you to structure the available space while keeping all areas connected – the feeling of spaciousness remains. Whether it's a home office or a hotel room,

people can experience the space in its entirety at all times: regardless of where they are within in the room. With UNIQUIN, divided rooms appear to gain size, light and ambience. This conveys a feeling of luxury, especially where space must be used efficiently.



With its open design, UNIQUIN scores highly wherever a view into neighbouring rooms is desirable – for example in fitness suites. The acoustic modules can be individually printed, offering visual highlights as well as enhancing the ambient sound of the space.

### Large rooms acoustically separated, visually unified

With UNIQUIN, you create rooms that offer advantages in virtually any application. The modular system enables you to divide areas without restricting the panoramic view and access to natural light. In terms of colour, UNIQUIN fits almost any environment. The absorption

of sound can be greatly enhanced by the use of optional acoustic modules. The decoupled mounting system for the glass elements in the UNIQUIN profiles also reduces sound transmission from room to room. This makes UNIQUIN a universal solution for almost every space.

# Enhance your interior architecture

## For designers who prefer to set their own boundaries.

**UNIQUEIN is the perfect solution for architects, TGA planners and spatial planners who advise builders on the design of their buildings.**

With UNIQUEIN, you can configure spatial designs that stand out in terms of both quality and flexibility. The flush-fitting elements, with their slender styling, reveal excellence in both material and workmanship. The profiles can accommodate glass, but also other materials such as timber, in thicknesses from 10 to 19 mm. This allows you to adopt your own harmonious mix of transparent and opaque elements and combine panoramic views with discreet privacy.

### Perfect for the property

- Versatility when planning
- Integrated design of all components
- Sound protection up to 39 dB can be integrated in the system
- Aluminium profiles with resistant special graphite powder coating; other powder-coated surfaces available
- Option to install glass or other materials in thicknesses from 10 to 19 mm
- All components can be ordered from one system

## For installers who appreciate uncomplicated quality.

**Whether you're a tradesperson or a property planner – with UNIQUEIN, you can implement interior design across disciplines.**

UNIQUEIN allows you to implement sophisticated room concepts quickly and easily. The system can be easily installed with standard tools in rooms of all the usual heights up to 4000 mm. The component connections are fully coordinated and requisite cabling can be ducted through the profiles to make things even simpler. The profiles are available for delivery either in stock lengths (6000 mm) or custom-cut – just let us know your specifications when placing the order.



Simple to implement – with effortless assembly and custom-fit system components.

### Beautifully simple

- Installation with standard tools
- Coordinated construction connections
- Easy to repair, reconfigure or dismantle and re-install
- Standard room heights accommodated without any problem
- Profiles delivered from the factory in the required length or in 6000 mm warehouse length
- Integration of electrical / electronic connections possible
- Time- and cost-saving final assembly of the cover profiles across all trades (e.g. by electrician) at the end of construction
- Self-explanatory assembly videos available

### Do you have any design or technical questions?

We look forward to hearing from you:  
[www.dorma-glas.com](http://www.dorma-glas.com)

With regard to the suitability of the system in damp rooms or for outdoor use, please refer to the safety-related information on page 67.



# Basic versions

With UNIQVIN, you can create an interior design exactly to your taste – from comprehensive room concept to individual door solution.

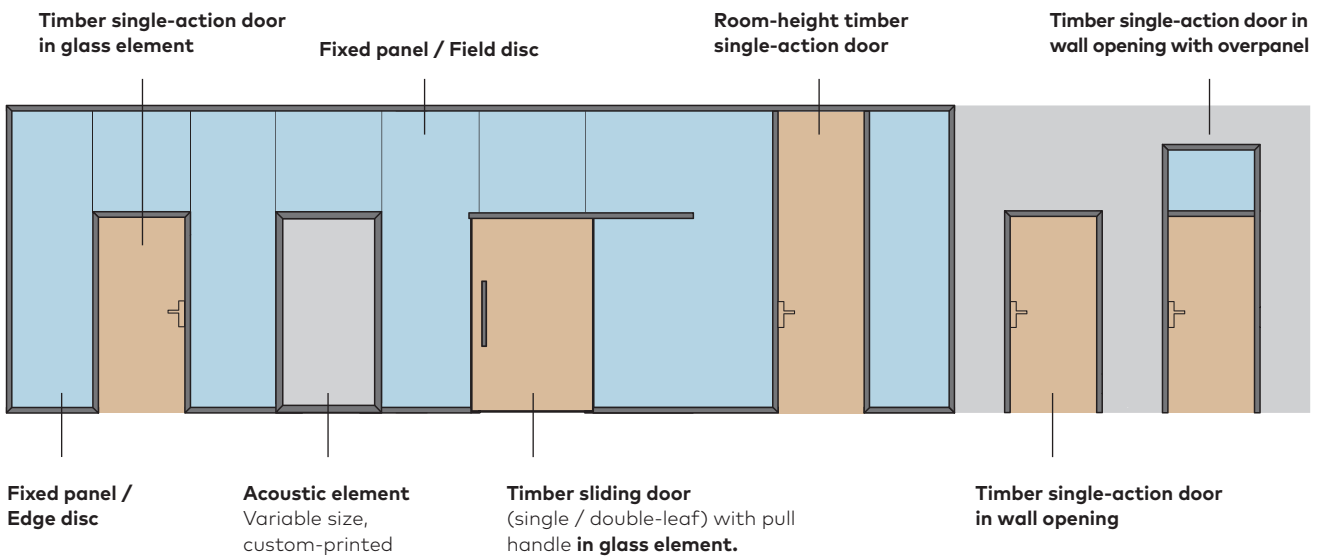
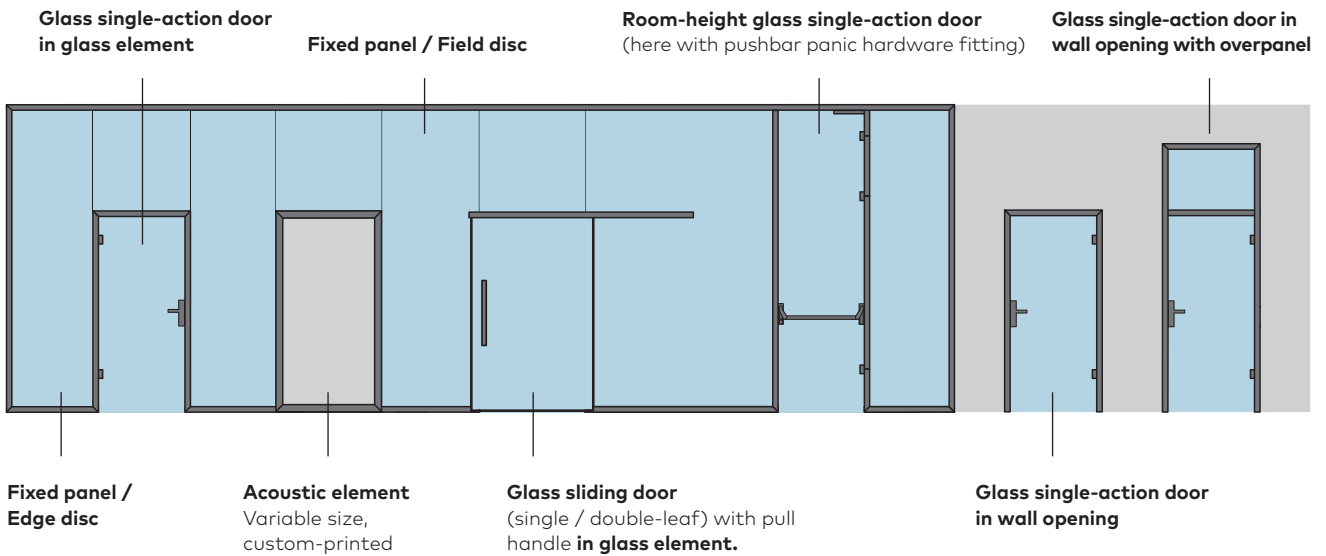

**Note:** On-site timber door leaf, lock and hinges.

# System types

These standard systems represent a selection of the possibilities.

Individual configurations can be realized in consultation with our application technology department.

## Glass

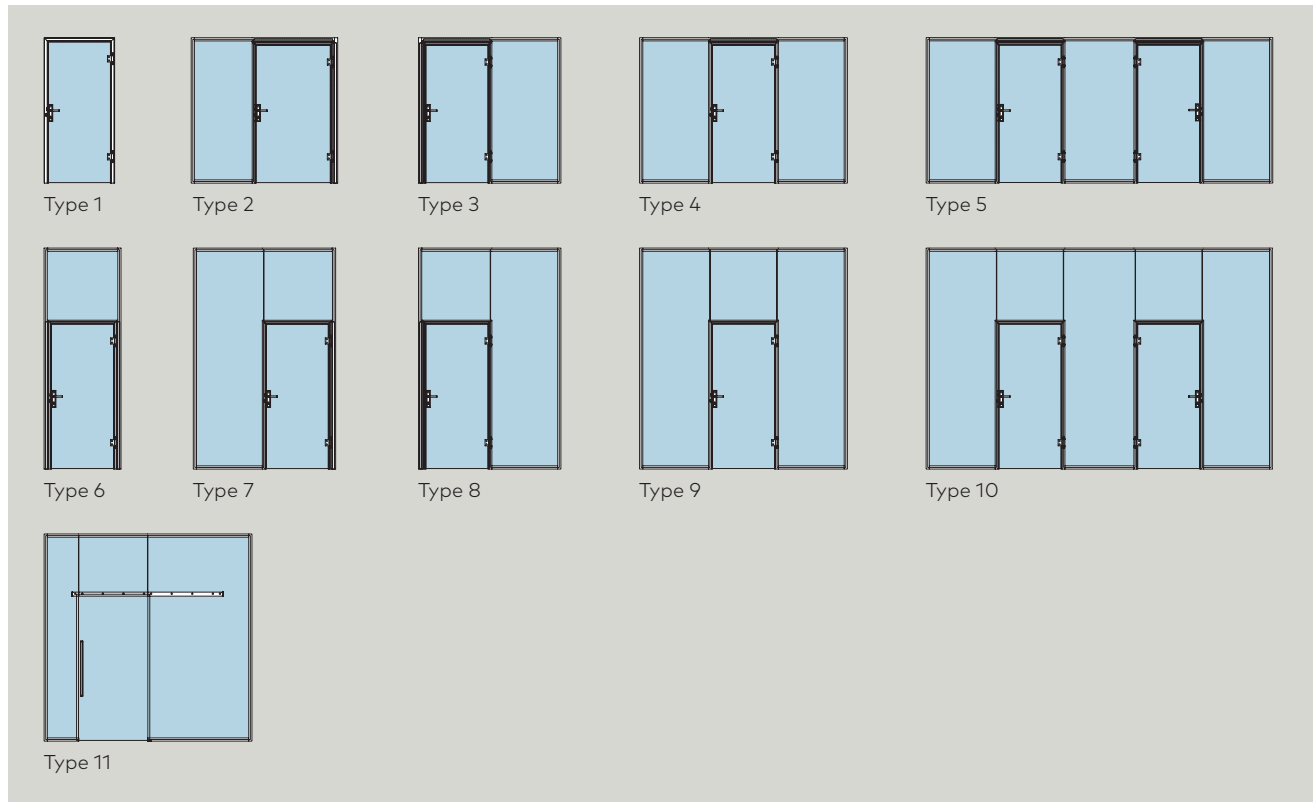

## Timber

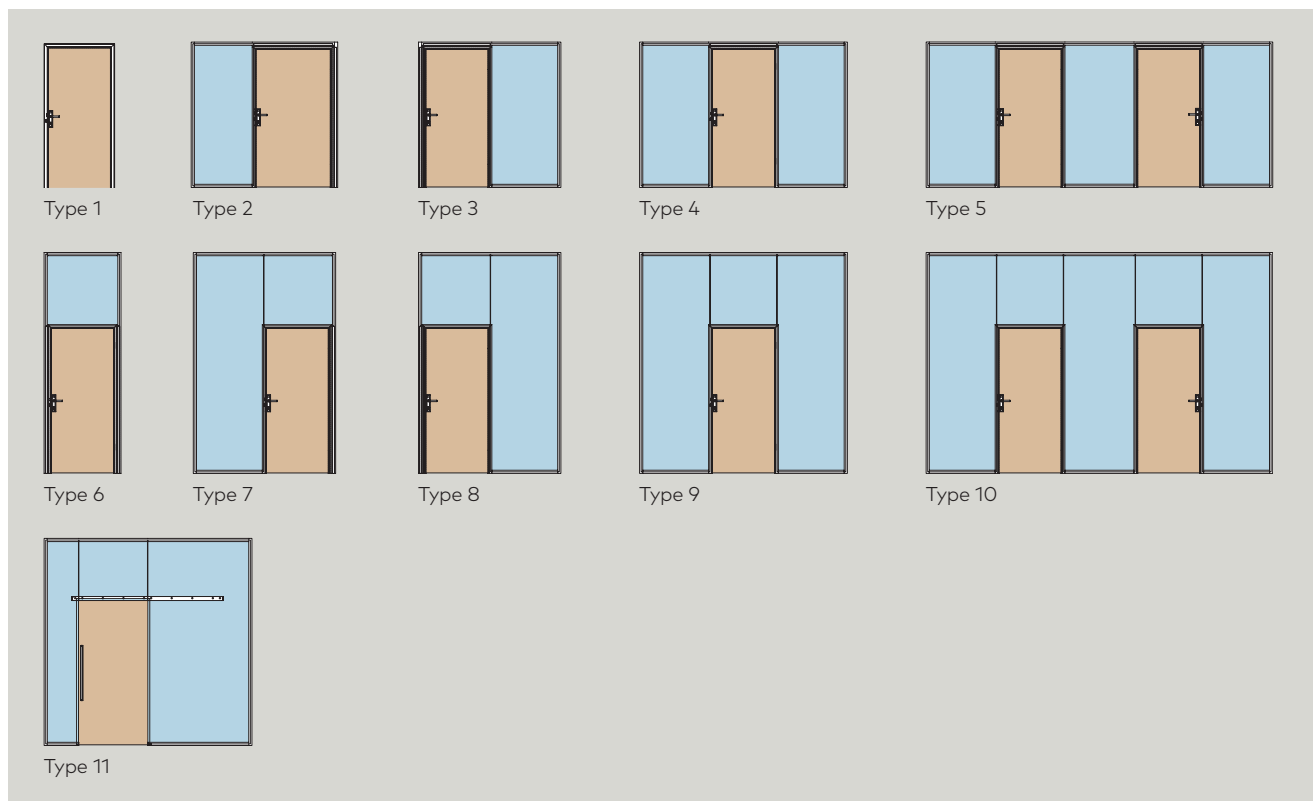



# General – Technical data

When planning systems, the system width and the max. height must be determined with regard to the corresponding glass statics. In addition, the maximum height of the system depends on the thickness of the glass.

<b>Total system measurements taking into account the glass statics</b> (b = width, h = height)	w = no limit (according to respective glass statics) h = max. 4000 mm
<b>Intermediate fixed panel</b> <b>Wall-mounted fixed panel</b>	w = min. 500 mm, h = max. 4000 mm w = min. 300 mm, h = max. 4000 mm (See also "Maximum installation heights" table)
<b>Pane material</b> (TSG = single-pane safety glass, LSG = laminated safety glass)	Glass (TSG, LSG of 2 x TSG), timber or other material (10 – 19 mm)
<b>Mounting profiles</b>	For material thicknesses 10 – 13.5 mm, 14 – 18 mm and 16 – 19 mm (see page 24)
<b>Profile material and colours</b> (AL = Aluminum)	Aluminium, powder-coated
	385 AL powder coated, Jet black, fine texture, matte (sim. RAL 9005)
	384 AL powder coated, Traffic white, smooth, flat matte (sim. RAL 9016)
	382 AL powder coated, Graphite, fine texture, matte (scratch resistant)
	383 AL powder coated, similar DB 703, smooth, matte, perl glimmer effect
	318 AL powder coated, similar anodized EV1, smooth, matte
	399 AL powder coated, Special color. (Standard powder according to the corresponding overview on our website. A price surcharge is possible for special colors outside the color range specified there.)
<b>Installation options</b>	Wall, floor, ceiling, 90° room corner, T-joint
<b>Door types</b>	Swing and sliding doors (technical data from page 34)
<b>Emergency exit / panic function</b>	In accordance with EN 179 and EN 1125 (can be equipped optionally, see from page 52)
<b>Wiring</b> (electrics / electronics)	Integrated cabling of NYM cables with max. outside diameter of 10 mm
<b>Sound protection test</b> (dB = decibel)	Tested sound protection according to DIN EN ISO 10140 up to 41 dB, depending on design and construction type. (The sound protection value may vary depending on the chosen glass thickness. The specified value of up to 39 dB refers to a complete door element and thus to the supposedly weakest element of an assembly. Up to 41 dB can be achieved in the fixed panel area. Corresponding certificates are available upon request, see page 15.)
<b>Structural analysis</b>	Proof of stability according to DIN 18008. DIN 4103 available as certificate for glass. (For alternative materials, the safety certificate must be furnished on a case-by-case basis.) Accident-proof glazing possible with UNIQUIN, see note on page 12/14.



Technically, almost anything is possible – UNIQUIN from DORMA-Glas

## Maximum installation heights

**Note:** Please contact us to obtain our stability certificate for glass. We can also provide you with information on the use categories and other corresponding maximum values. Please note the installation areas according to the usage category chosen by the customer on the following page.

To find your contact person,  
simply go to:  
[www.dorma-glas.com](http://www.dorma-glas.com)



# UNIQUIN structural stability calculations

## Use categories with corresponding max. system height

			Installation area in accordance with DIN 4103		
			1	2	
			Use category in accordance with ETAG 003		
			I	II	III
			100 Nm	200 Nm	300 Nm
Width 500 mm		Height (mm)			
10	ESG	3300	●	○	○
		3000	●	○	○
		2500	●	●	○
10,76	VSG	3300	●	○	○
		3000	●	●	○
		2500	●	●	●
11,52	VSG	3300	●	○	○
		3000	●	●	○
		2500	●	●	●
12	ESG	3300	●	○	○
		3000	●	●	○
		2500	●	●	●
12,76	VSG	3300	●	●	○
		3000	●	●	○
		2500	●	●	●
13,52	VSG	3300	●	●	○
		3000	●	●	○
		2500	●	●	●
15	ESG	4000	B	X	X
		3500	B	X	X
		3300	B	X	X
16,76	VSG	4000	B	X	X
		3500	B	X	X
		3300	B	X	X
17,52	VSG	4000	B	X	X
		3500	B	X	X
		3300	●	●	●
19	ESG	4000	B	X	X
		3500	B	X	X
		3300	B	X	X

UNIQUIN offers fall protection glazing options. For further information, please get in touch with your contact person in sales or in our application technology department. For more information, see page 14.

● = static / dynamic, calculated according to standard and physically tested    B = static / dynamic, calculated according to standard  
 ○ = not permitted    X = under review



# UNIQUIN stability certificate

UNIQUIN is linear-mounted glazing (LV)\* and thus only suitable for vertical glazing. The following illustrations show possible glass bearing arrangements. With UNIQUIN, only the last case is permissible. The glass is properly stored by providing it with glazing profiles at the bottom and top.

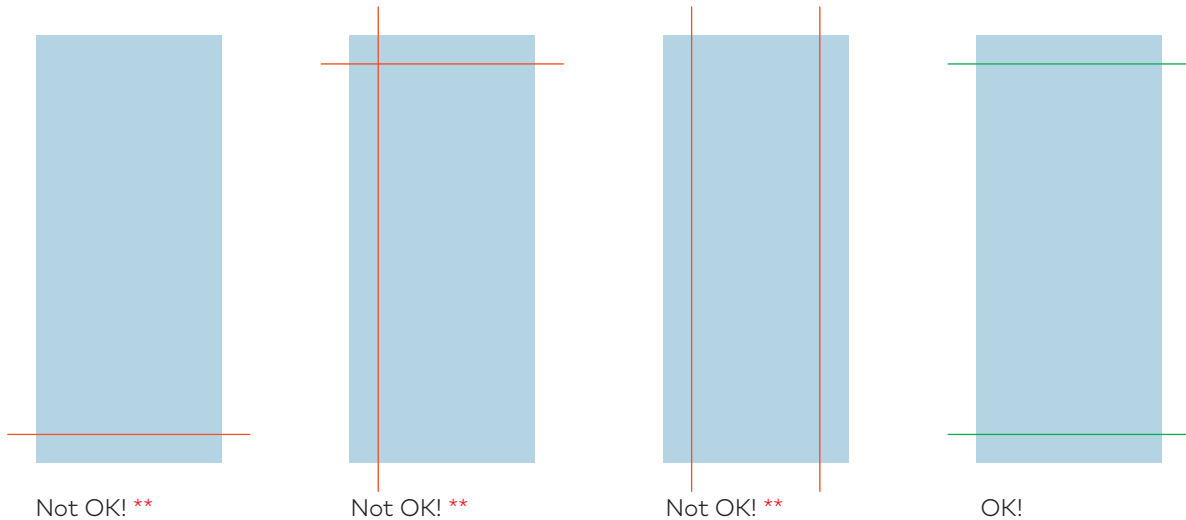

## Notes on the stability of UNIQUIN:

- The inclination of the system must be  $\leq 10^\circ$ .
- Only temporarily variable loads may be applied to the LV.
- The glass must be properly blocked.

## UNIQUIN is not suitable for walkable glazing and/or horizontal glazing.

Examples include:

- Overhead glazing
- Canopy

## Information about the use categories of DIN 4103

### Installation area 1

- Areas that are mainly accessible to people who exercise a high degree of caution. Examples: rooms in residential buildings, offices; hospital wards. Minimal risk of accident and misuse.
- Areas that are mainly accessible to people with some degree of caution. Examples: rooms in residential buildings, offices; hospital wards. Medium risk of accident and misuse.

### Installation area 2

- Areas that are easily accessible to the public and to persons who exercise a minimum degree of caution. Examples: schoolrooms, meeting rooms, reception rooms, entrance areas in hotels or administrative buildings, lecture halls, waiting rooms; areas in cafes, restaurants, cinemas; sports and recreation areas such as dance halls, sports halls, stages; areas in department stores, shops; storage areas including libraries. Risk of accident and misuse.

\* DIN 18008 Part 1 and Part 2

\*\* UNIQUIN is not permitted for these installations.

## ETAG 003 definition of use categories – Structural damage – Dynamic loads according to ETAG 003

- Areas that are mainly accessible to people who exercise a high degree of caution. Minimal risk of accident and misuse.
- Areas that are mainly accessible to people who exercise a medium degree of caution. Medium risk of accident and misuse.
- Areas that are easily accessible to the public and to persons who exercise a minimum degree of caution. Risk of accident and misuse.
- Areas and risk as for II and III. In case of malfunction, there is a risk of falling to a lower floor.

## Installation recommendation

The minimum glass mounting depth is 20 mm. In the case of extreme impact load (result of a pendulum impact test), the glass may slide out of the upper profile. It is therefore recommended to plan a glass mounting depth of 23 mm or, for safety reasons, to maintain the maximum possible glass mounting depth in the upper area.

**Static detection of supporting forces (supplementary note)**

Calculation examples for a 5000 mm system height were carried out. Based on experience and in order to minimize the supporting loads, the maximum system height was reduced to 4000 mm. Depending on the load case and the system height, the supporting loads per metre are determined and distributed over three connecting elements. The on-site substrate determines the selection of the connecting elements to be provided by the customer. In any case, the UNIQUIN system requires a substructure with sufficient load-carrying capacity. If, for example, the ceiling is concrete, the material, strength, type of drill hole and installation must be considered. Software solutions and online consulting are offered by major connection manufacturers.

If the calculated supporting load on the three connecting elements is too high, the load can, in exceptional cases, be distributed over four or five connecting elements by adding additional drill holes. This must be planned on site.

The load forces for the correct dimensioning and selection of the connecting element can be taken from the static proof. The calculation can be understood on the basis of the example shown.

**Note:** Please ask for our proof of stability for the glazing.

Wall-mounted and three sided fixed panels are basically more stable and stiffer than intermediate fixed panels. Therefore they have different minimum widths. See table on page 11.



**UNIQUIN as fall-proof glazing according to DIN 18008-4**

With the UNIQUIN system, fall-proof glazing is also possible. However, in principle proof of usability under building law must be provided. On the basis of a corresponding general building authority test certificate P-2021 – 3023 you are on the safe side with UNIQUIN. Depending on the glass structure (composition of LSG), glass dimensions (height and width) and depending on the storage of the glazing in UNIQUIN fixed parts (2-, 3- or 4-sided), fall-proof solutions can be realised up to an installation height of 3300 mm. We will be happy to provide you with the test certificate on request. Please get in touch with your contact person in the field service or in the application technology.

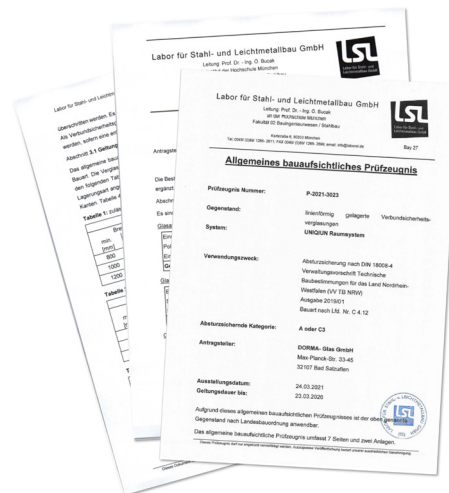

**LSG Glass structure for fall-proof glazing**

LSG Glass structure			three or four-sided storage		two-sided storage	
Glass	Film	Glass	Min. width	Max. height	Min. width	Max. height
TSG 8	Polyvinyl-Butyral film (PVB) 0.76 mm	TSG 8	300	3000	800	2454
					1000	2750
TSG 8	Sentry glass SG 5000 1.52 mm	TSG 8	300	3300	1200	3000
					800	3000
					1000	3200
					1200	3300

# Technical information on sound insulation

UNIQUIN reduces the transmission of sound between adjacent rooms by decoupling the profile and the separating element as well as the profile and the building structure. The use of special glazing enables noise reduction values of up to 41 dB.

Sound insulation loss of common solid glazing elements with UNIQUIN profiles was tested in the laboratory. A sound insulation loss of only 1 dB from the sound value of the glass manufacturer's specification was detected.

 The human ear only perceives a change in sound level above 3 dB.

In other series of measurements, single-action doors with equally large glass elements were tested (see page 19).

In the case of single-action doors with drop-down seals, losses of sound insulation values of 2 to 4 dB were measured compared to solid glazing elements.

The sound insulation values for additional glass thicknesses can be derived from existing expert reports based on the findings of further tests (see Table below and from page 19).

## Sound insulation measurement on the test bench

The sound insulation measurement according to DIN EN ISO 10140-2 is for direct sound transmission.

**Note:** Flanking transmission and installation conditions may influence the result.

## Schematic illustration sound insulation measurement according to DIN EN ISO 10140-2

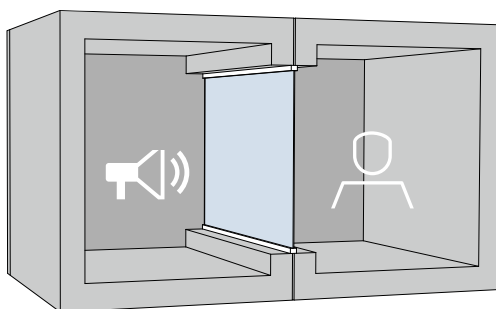

Source room

Receiving room

## Average sound insulation value from the glass industry

Glass type	Glass thickness (t in mm)	Individual values and spectrum adjustment values		
		Rw (dB)	C (dB)	Ctr (dB)
Single-glazing <b>TSG</b>				
	10	33	-2	-3
	12	34	0	-2
LSG structure with sound-absorbing film	Glass / PVB / glass (mm)			
	5 / 1.52 / 5	39	-1	-3
	6 / 1.52 / 6	40	-2	-3
	8 / 1.52 / 8	42	-1	-3

## Perception of noise reduction

Noise reduction (dB)	Perception
0 – 2	imperceptible
3 – 5	just perceptible, small improvement
6 – 10	clearly perceptible, noticeable improvement
11 – 20	significant, convincing improvement
> 20	very significant, very convincing improvement

**Note:** For construction projects with noise protection requirements, we recommend you request the test certificates from the glass manufacturer.



# Comparison of noise sources and perception

## Noise protection

Office  
no noise protection

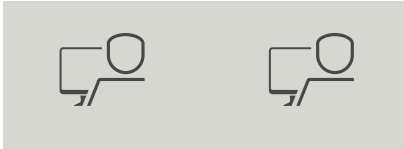

60–70 dB

Conversation next to the bedroom  
with sound protection by UNIQUIN

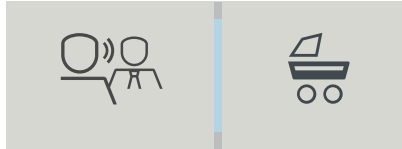

50–60 dB >> 10–20 dB\*

Office next to office with  
sound protection by UNIQUIN

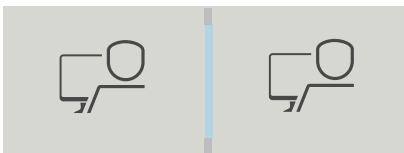

60–70 dB >> 20–30 dB

Conversation next to library  
with sound protection by UNIQUIN

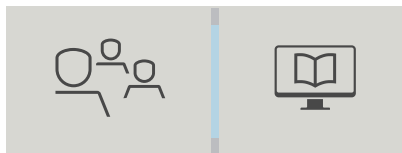







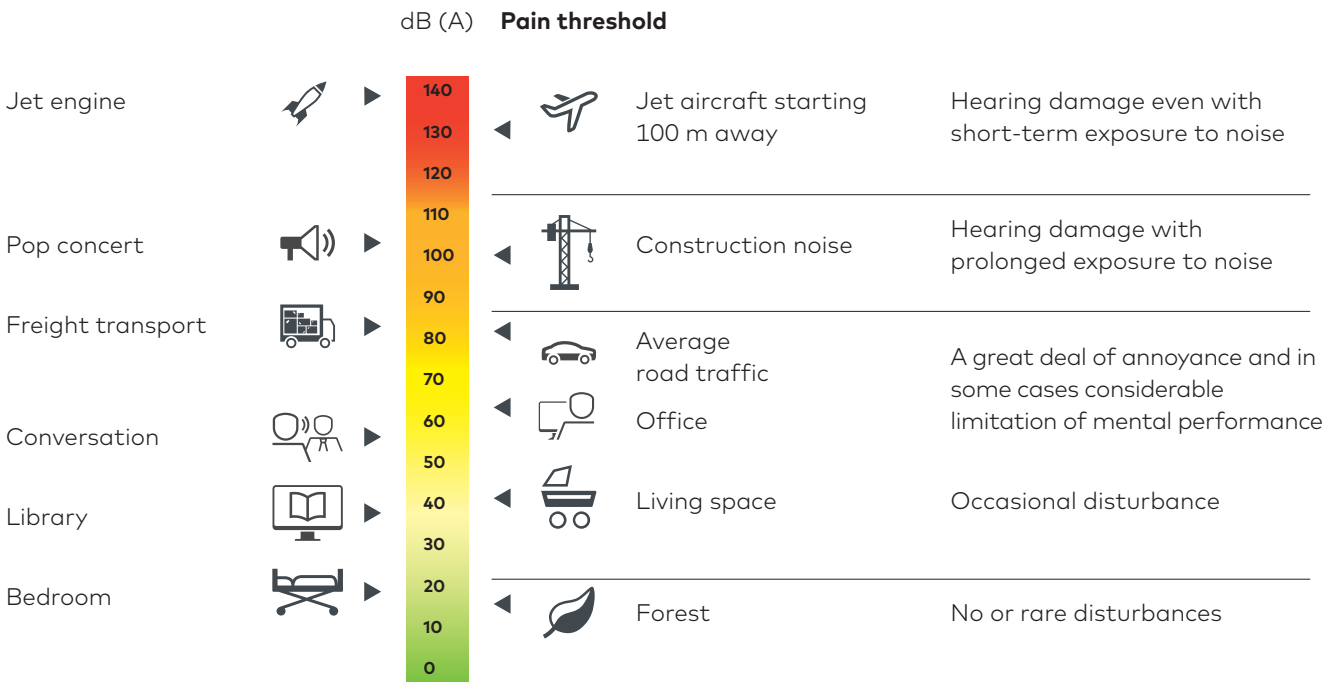





70–80 dB >> 30–40 dB

\*Specification according to standard DIN EN 15251:2012-12  
Please note the sound insulation values from page 19.

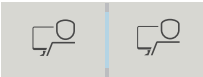
## Sound pressure level of various sound sources and sound effects



**Information on sound protection in everyday situations**

			<b>Impacts and measures</b>	<b>Door solution</b>	<b>Volume</b>
			Low sound protection, sliding door without any sealing elements	Sliding door	You can follow a conversation at normal volume in the neighbouring room
			Slightly increased sound insulation, sliding door with gaps	Sliding door	You cannot follow a conversation at normal volume in the neighbouring room, but you do hear that a conversation is taking place
			Low sound protection, single-action door with TSG glazing, without drop-down seals	Single-action door	You can follow a conversation at normal volume in the neighbouring room
			Slightly increased sound protection, single-action door with TSG glazing and drop-down seals	Single-action door	You cannot follow a conversation at normal volume in the neighbouring room, but you do hear that a conversation is taking place
			Increased sound protection, single-action door with LSG glazing and drop-down seals	Single-action door	You cannot follow a conversation even at a higher volume in the neighbouring room, but you do hear that a conversation is taking place
			Significantly increased sound protection, single-action door with LSG glazing (incl. sound-absorbing film), double gap seal and drop-down seals	Single-action door	You cannot hear a conversation even at a higher volume in the neighbouring room
			Slightly increased sound protection, fixed glazing with TSG glazing	Fixed glazing	You cannot follow a conversation at normal volume in the neighbouring room, but you do hear that a conversation is taking place
			Slightly increased sound protection, fixed glazing with LSG glazing	Fixed glazing	You cannot follow a conversation even at a higher volume in the neighbouring room, but you do hear that a conversation is taking place
			Significantly increased sound protection, fixed glazing with LSG glazing (incl. sound-absorbing film)	Fixed glazing	You cannot hear a conversation even at a higher volume in the neighbouring room

# Space for your notes



# DORMA-Glas inspection report

The following tests were carried out with UNIQUIN in accordance with DIN EN ISO 10140-2. The test documents are available on request.

## Test results

### Sound insulation measurement according to DIN EN ISO 10140-2

Glass	Dimensions		Corrected measurement	Remark
	Clear passage width [W] (mm)	Clear passage height [LH] (mm)	Rw (C; Ctr)	
<b>Fixed glazing</b>				
12 mm TSG	1000	2125	35 (-2; -3) dB	Single-pane fixed glazing with 46 mounting profile
12 mm LSG SC 66.4	1000	2125	39 (0; -2) dB	Single-pane fixed glazing with 46 mounting profile
16 mm LSG SC 88.4	1000	2125	41 (-1; -2) dB	Single-pane fixed glazing with 46 mounting profile
<b>Single-action door*</b>				
12 mm TSG	1000	2125	31 (-1; -1) dB	Single-action door with drop-down seal
12 mm LSG SC 66.4	1000	2125	35 (-1; -1) dB	Single-action door with drop-down seal
16 mm LSG SC 88.4	1000	2125	39 (-1; -2) dB	Single-action door with drop-down seal
<b>Sliding door</b>				
10 mm TSG	1000	2125	12 (-1; -1) dB	Without brush seal and floor seal
12 mm LSG SC 66.4	1000	2125	13 (-1; -1) dB	Without brush seal and floor seal
10 mm TSG	1000	2125	14(-1; -1) dB	With three-sided brush seal and without floor seal
12 mm LSG SC 66.4	1000	2125	14(-1; -1) dB	With three-sided brush seal and without floor seal
<b>Fixed glazing</b>				
16 LSG SC 88.4	3570	2910	38 (±1.2) dB	Six-pane fixed glazing with 55 mounting profile, the same values can be achieved with the 46er pick-up profile (still untested).
<b>Single-action door with sidelight</b>				
16 LSG SC 88.4	3670	2910	36 (±1.2) dB	Fixed glazing consisting of five elements with 55 mm mounting profile + pivoting door and overpanel, the same values can be achieved (not yet tested).
<b>Acoustic element</b>				
16 LSG SC 88.4	1230	1480	41 (±1.2) dB	Acoustic element with glass element and convoluted foam insulation

\*To improve the usability of the single-action doors, the leaf opening seal may be dispensed with. In that case, an additional loss of sound insulation of  $\leq 1$  dB is to be expected (see page 66).

All LSG glazing was tested with SC (special sound-absorbing film).

**Note:** Sound protection certificates available on request!

# DORMA-Glas manufacturer's test certificate

## Sound insulation measurement according to EN ISO 10140-2

Glass	Design	
<b>Fixed glazing</b>		
12 mm TSG	<ul style="list-style-type: none"> <li>• Mounting profile: 46 mm</li> <li>• Fixed element height: 2125 mm</li> <li>• Fixed element width: 1000 mm</li> <li>• Glass height: 2079 mm</li> <li>• Glass width: 954 mm</li> <li>• Glass thickness: 12 mm</li> <li>• Glass type: TSG</li> </ul>	Rw (C; Ctr) 35 (-2; -3) dB Reference: Report of measurement of airborne sound insulation (20180710_Prüfbericht UNIQUIN Schalldämmwert Messungen Firma Athmer)
13.5 mm LSG	<ul style="list-style-type: none"> <li>• Mounting profile: 46 mm</li> <li>• Fixed element height: 2125 mm</li> <li>• Fixed element width: 1000 mm</li> <li>• Glass height: 2079 mm</li> <li>• Glass width: 954 mm</li> <li>• Glass thickness: 13.52 mm</li> <li>• Glass type: LSG with sound-absorbing film (66.2)</li> </ul>	Rw(C; Ctr) 39 (0; -2) dB Reference: Report of measurement of airborne sound insulation (20180710_Prüfbericht UNIQUIN Schalldämmwert Messungen Firma Athmer)
17.5 mm LSG	<ul style="list-style-type: none"> <li>• Mounting profile: 46 mm</li> <li>• Fixed element height: 2125 mm</li> <li>• Fixed element width: 1000 mm</li> <li>• Glass height: 2079 mm</li> <li>• Glass width: 954 mm</li> <li>• Glass thickness: 17.52 mm</li> <li>• Glass type: LSG with sound-absorbing film (88.4)</li> </ul>	Rw (C; Ctr) 41 (-1; -2) dB Reference: Report of measurement of airborne sound insulation (20180710_Prüfbericht UNIQUIN Schalldämmwert Messungen Firma Athmer)
<b>Single-action door</b>		
12 mm TSG	<ul style="list-style-type: none"> <li>• Mounting profile: 46 mm with frame adapter</li> <li>• Clear passage height: 2125 mm</li> <li>• Clear passage width: 1000 mm</li> <li>• Glass height: 2023 mm</li> <li>• Glass width: 812 mm</li> <li>• Drop-down seal</li> <li>• Glass thickness: 12 mm</li> <li>• Glass type: TSG</li> </ul>	Rw (C; Ctr) 31 (-1; -1) dB Reference: Report of measurement of airborne sound insulation (20180710_Prüfbericht UNIQUIN Schalldämmwert Messungen Firma Athmer)
13.5 mm LSG	<ul style="list-style-type: none"> <li>• Mounting profile: 46 mm with frame adapter</li> <li>• Clear passage height: 2125 mm</li> <li>• Clear passage width: 1000 mm</li> <li>• Glass height: 2023 mm</li> <li>• Glass width: 812 mm</li> <li>• Drop-down seal</li> <li>• Glass thickness: 13.52 mm</li> <li>• Glass type: LSG with sound-absorbing film (66.4)</li> </ul>	Rw (C; Ctr) 35 (-1; -1) dB Reference: Report of measurement of airborne sound insulation (20180710_Prüfbericht UNIQUIN Schalldämmwert Messungen Firma Athmer)
17.5 mm LSG	<ul style="list-style-type: none"> <li>• Mounting profile: 46 mm with frame adapter</li> <li>• Clear passage height: 2125 mm</li> <li>• Clear passage width: 1000 mm</li> <li>• Glass height: 2023 mm</li> <li>• Glass width: 812 mm</li> <li>• Drop-down seal</li> <li>• Glass thickness: 17.52 mm</li> <li>• Glass type: LSG with sound-absorbing film (88.4)</li> </ul>	Rw (C; Ctr) 39 (-1; -2) dB Reference: Report of measurement of airborne sound insulation (20180710_Prüfbericht UNIQUIN Schalldämmwert Messungen Firma Athmer)

**Sound insulation measurement according to EN ISO 10140-2**

<b>Glass</b>	<b>Design</b>	
<b>Sliding door without brush seal</b>		
10 mm TSG	<ul style="list-style-type: none"> <li>• MUTO Comfort L 80</li> <li>• Clear passage height: 2125 mm</li> <li>• Clear passage width: 1000 mm</li> <li>• Glass height: 2163 mm</li> <li>• Glass width: 1060 mm</li> <li>• Glass thickness: 10 mm</li> <li>• Glass type: TSG</li> </ul>	Rw (C; Ctr) 12 (-1; -1) dB Reference: Report of measurement of airborne sound insulation (20180710_Prüfbericht UNIQUIN Schalldämmwert Messungen Firma Athmer)
13.5 mm LSG	<ul style="list-style-type: none"> <li>• MUTO Comfort L 80</li> <li>• Clear passage height: 2125 mm</li> <li>• Clear passage width: 1000 mm</li> <li>• Glass height: 2163 mm</li> <li>• Glass width: 1060 mm</li> <li>• Glass thickness: 13.52 mm</li> <li>• Glass type: LSG structure with sound-absorbing film (66.4)</li> </ul>	Rw (C; Ctr) 13 (-1; -1) dB Reference: Report of measurement of airborne sound insulation (20180710_Prüfbericht UNIQUIN Schalldämmwert Messungen Firma Athmer)
<b>Sliding door with brush seal</b>		
10 mm TSG	<ul style="list-style-type: none"> <li>• MUTO Comfort L 80</li> <li>• Clear passage height: 2125 mm</li> <li>• Clear passage width: 1000 mm</li> <li>• Glass height: 2163 mm</li> <li>• Glass width: 1060 mm</li> <li>• Three-sided brush sealing</li> <li>• Glass thickness: 10 mm</li> <li>• Glass type: TSG</li> </ul>	Rw (C; Ctr) 14 (-1; -1) dB Reference: Report of measurement of airborne sound insulation (20180710_Prüfbericht UNIQUIN Schalldämmwert Messungen Firma Athmer)
13.5 mm LSG	<ul style="list-style-type: none"> <li>• MUTO Comfort L 80</li> <li>• Clear passage height: 2125 mm</li> <li>• Clear passage width: 1000 mm</li> <li>• Glass height: 2163 mm</li> <li>• Glass width: 1060 mm</li> <li>• Three-sided brush sealing</li> <li>• Glass thickness: 13.52 mm</li> <li>• Glass type: LSG structure with sound-absorbing film (66.4)</li> </ul>	Rw (C; Ctr) 14 (0; 0) dB Reference: Report of measurement of airborne sound insulation (20180710_Prüfbericht UNIQUIN Schalldämmwert Messungen Firma Athmer)



# Planning basics

## Planning specifications for the fixed glazing

- Only right-angled UNIQUIN systems can be ordered. Adjustments for sloping wall or floor / ceiling gradients are to be implemented by the customer (see section "Measuring correctly" on page 65).
- The product may only be attached to a supporting surface using suitable mounting material (see "The Detail" 50-022, on-site mounting material).
- Glass thickness must be selected according to the UNIQUIN stability certificate (see page 12 or "The Detail" 50-000B).
- Release drawings show the view from inside\*\*.
- Gaps are planned as 3 mm as standard. An on-site filling with coordinated silicones or the use of double-sided tape (e.g. tesa ACXplus) is possible. On request, systems with a gap of 5 mm can also be planned. This may be useful for large glass thicknesses, LSG and/or high manufacturing tolerances of the glasses. The customer must take into account any differences in the gap dimensions in the glass widths calculation. It is recommended to connect the glass with a wet seal or with double-sided adhesive tape.
- Profile connection to the building body in 90° installation. Different angles are to be implemented by on-site construction.

- In systems with sound-protection design, the glass joint must be sealed by the customer or with technical sealing tape, e.g. tesa ACXplus (see page 57).

## Specification by the glass industry:

For the production of a single glass pane (TSG = single-pane safety glass), the glass industry specifies a height-to-aspect ratio of 1:10. Unless otherwise stated, these specifications will be implemented in our release drawings.

- Systems > 6000 mm are divided (max. bearing length = 6000 mm). Profile joints are only permitted on a fixed panel and should be avoided on the overpanel and glass joint.
- Mitres and T-joints must be performed by the customer. Here, depending on the situation, profiles must be prepared (notch, see illustration at the bottom of page 25).
- Systems with a room corner and/or a T-joint have to be ordered with extra length to adjust the profile joints on site (see Figures 2+3, page 23).

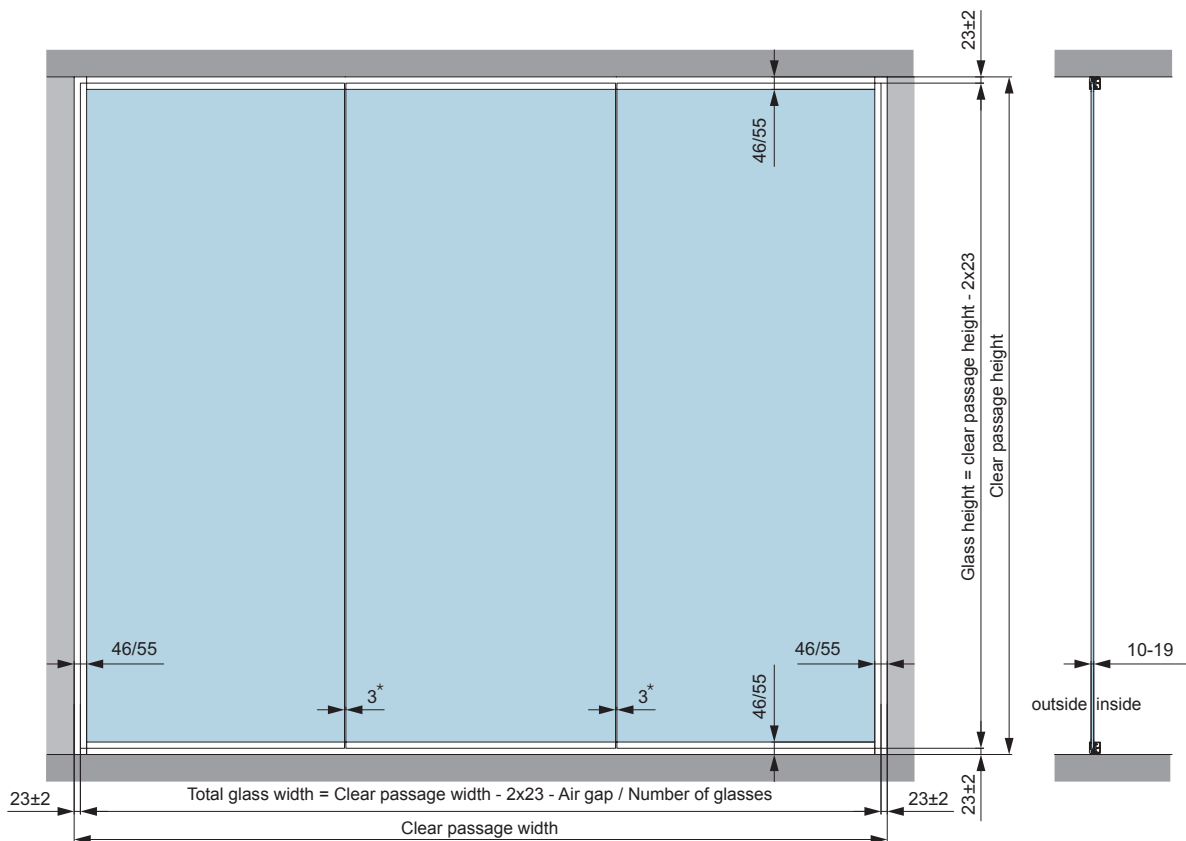

\* The dimensions of the gaps between the glass are based on the recommended system standard dimensions. The gap dimensions can be changed on site, taking into account the glass widths.

\*\*Release drawings show the view from the inside in each case: Cover profile side for fixed elements and hinge side for hinged doors, as well as rear side for sliding doors (see figures 1 to 3 on the next page).

**Recommendation:**

We recommend that you use doors with a overpanel for optimal handling, planning freedom and delivery reliability. Rooms have different heights. The use of overpanels allows for easy adjustment of the distance from door to ceiling without changes to the frame look. The design of the system and the transparent appearance remain intact, and installation is flexible. Toughened glass doors are also independent of the direction of DIN. We recommend a frame size of 1010 mm x 2155 mm for a barrier-free passage width. Profiles for systems with a room corner and/or T-joints must be ordered with extra length in order to adapt the profile joints on site (see figures below).

**Explanation of delivery length:**

Pre-cut systems can be ordered from the following options:

**1. Delivery in fixed length:**

All profile lengths and the frame are manufactured and delivered to exactly match the drawing. An exact measurement is a prerequisite. The connections must be parallel and perpendicular.

**2nd Delivery with extra length of 20 mm:**

Compared to the drawing, all mounting frames (except functional elements) are delivered with an extra length of 20 mm. Minor adjustments are possible on site. Sufficient for sloping walls / ceiling / floor.

**3. Delivery with extra length according to customer request:**

Compared to the drawing, all mounting frames (except function elements) are supplied with an extra length according to the customer's specification. On-site adjustments are possible. We recommend an extra length of 100 mm for angled systems.

**4. Delivery in standard length (recommended for buildings):**

The functional elements are supplied exactly as per the drawing. The mounting frames are ordered in a 6000 mm standard length. This enables an absolute flexibility during assembly.

**Note:** A profile joint is necessary if the system is wider than 6000 mm.

**Attention:** For all mounting points, specialist planning on site and a sufficiently stable base with coordinated dowel technology is required. Glass dimensions are to be provided by the customer prior to implementation.

Figure 1

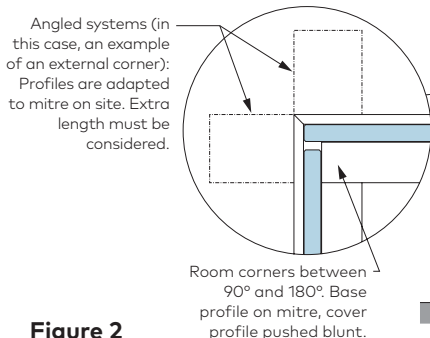
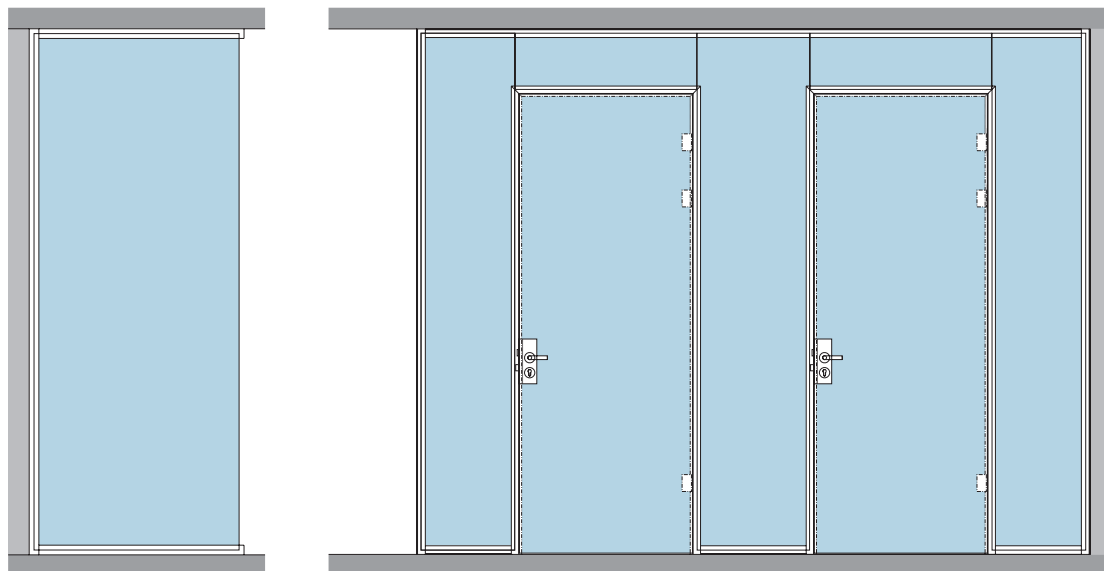

Figure 2

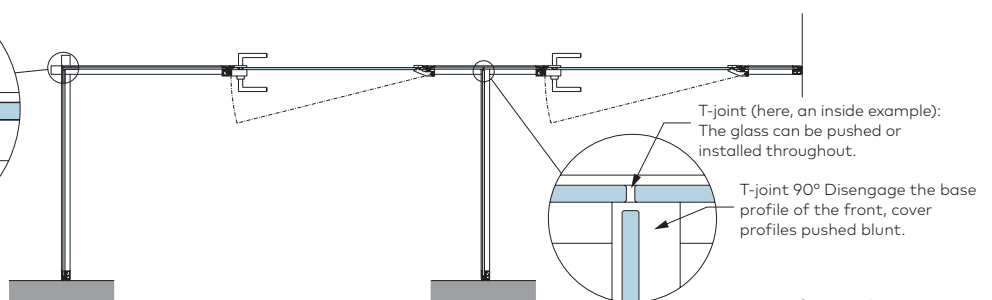

Figure 3

# Profile system technology

## Mounting profiles and information on the fixed elements

The mounting frames form the basis of the UNIQUIN system. Three available versions ensure optimal fixation of single-pane and laminated safety glass (TSG) as well as alternative materials with a thickness of 10 to 19 mm. The silicone seals decouple the glass from the profile and the profile from the building.

The profile cross-section allows cables with a diameter of up to 10 mm to be mounted (see page 50).

## Base profile versions

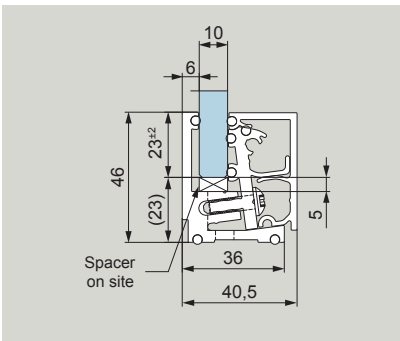

**46/36 profile**  
46 mm visible height  
10 – 13.5 mm material thickness

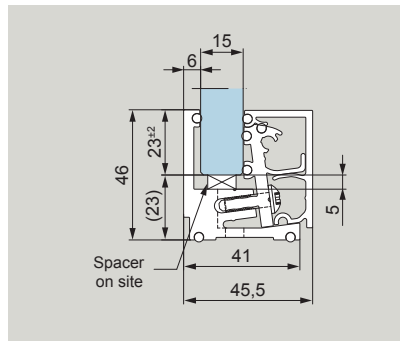

**46/41 profile**  
46 mm visible height  
14 – 18 mm material thickness

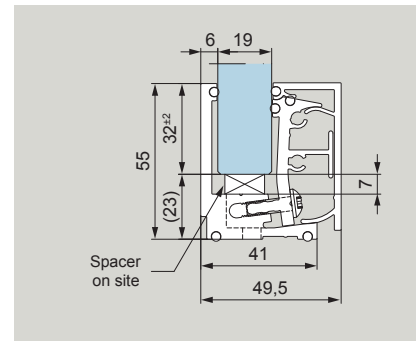

**55/41 profile**  
55 mm visible height  
16 – 19 mm material thickness

## Usable glass thicknesses (shown as an example)

### Mounting profile 46/36 mm, glass 10 – 13.5 mm

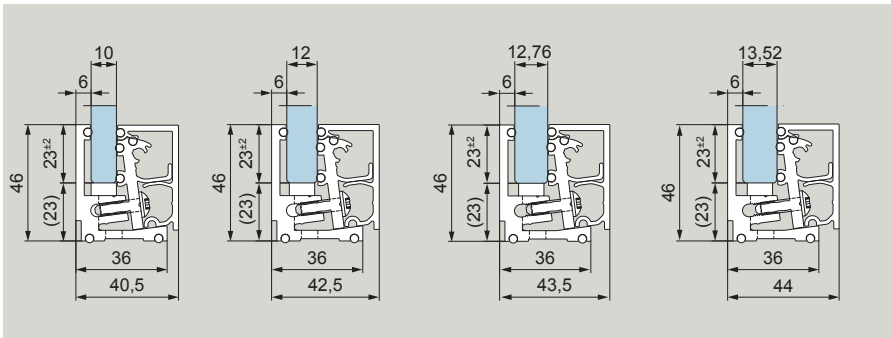

### Mounting profile 46/41 mm, glass 14 – 18 mm

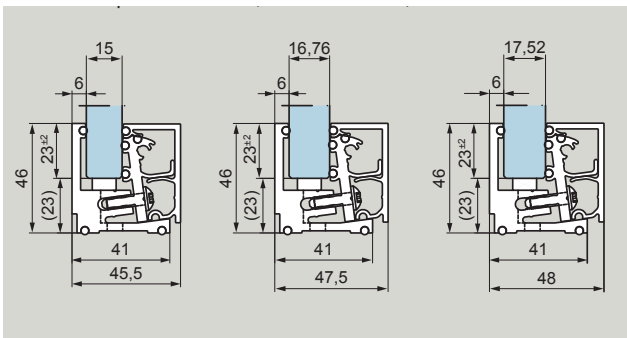

### Mounting profile 55/41 mm, glass 16 – 19 mm

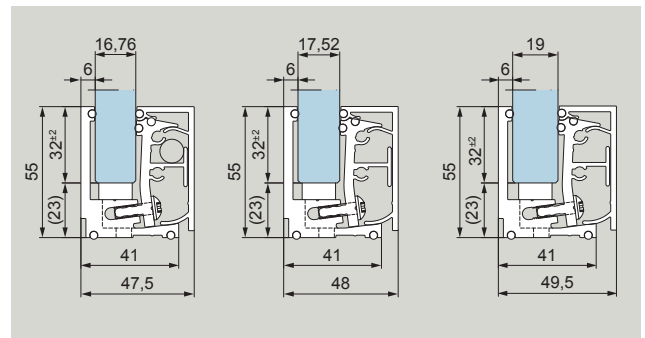



**Note:** We recommend maintaining an excess length of at least 100 mm for T-joints and for performing the on-site system preparation. Room corners are not possible in direct connection to doors. The cutting takes place on site.

**Details of 90° corner**

- 90° external corner
- Outside base profile – mitre connection
- Inside cover profile – butt joint
- 90° internal corner
- Inside base profile – mitre connection
- Outside cover profile – mitre connection

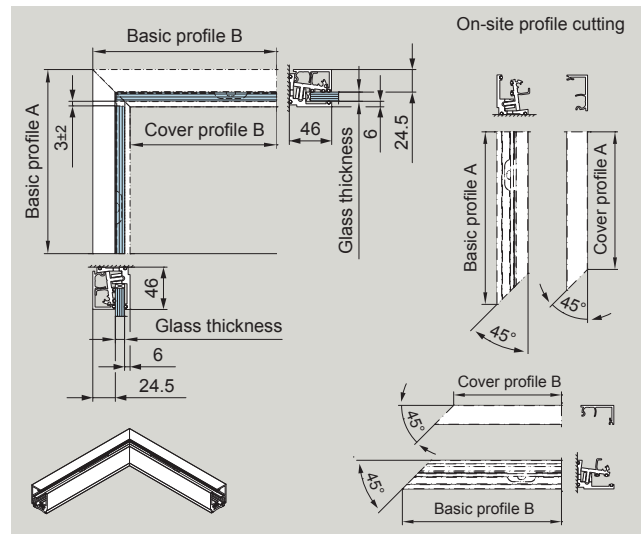
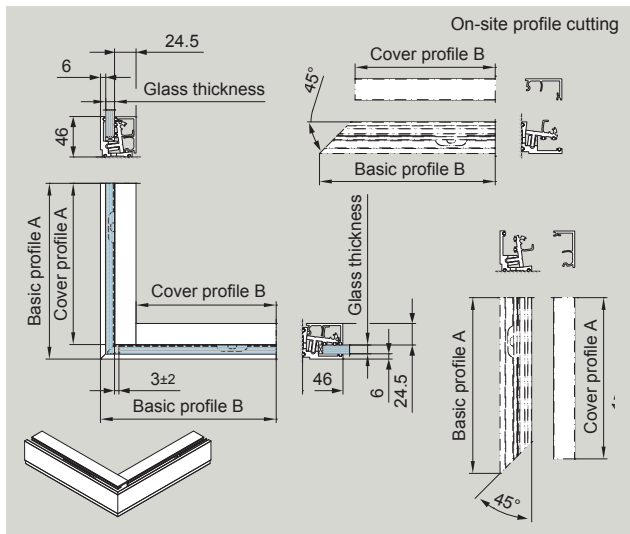

**Details of T-joint**

- T-joint outside
- Outside base profile – butt joint
- Inside cover profile – butt joint
- T-joint inside
- Outside base profile – butt joint
- Inside cover profile – butt joint

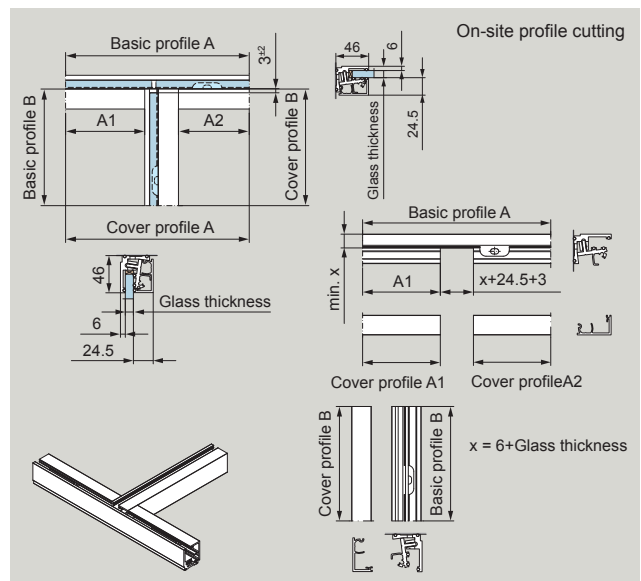
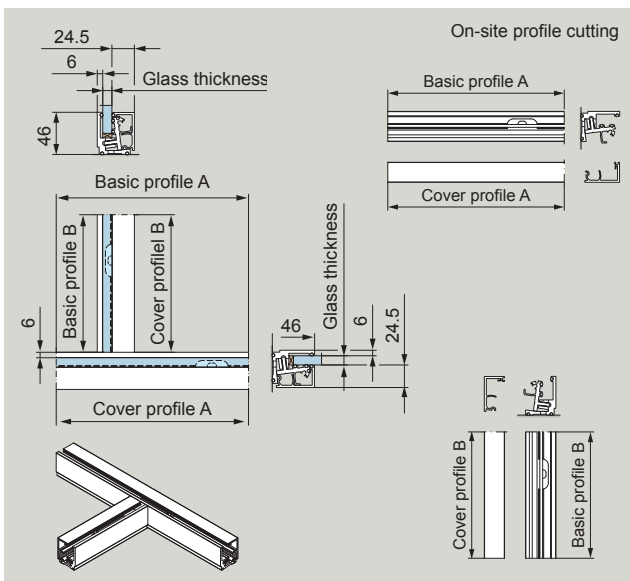

Watch the UNIQUIN joint (room corners) assembly video (video 6):



# Fixed glazing technology

UNIQUIN is linear-mounted glazing and thus only suitable for vertical glazing.

## Straight system configuration

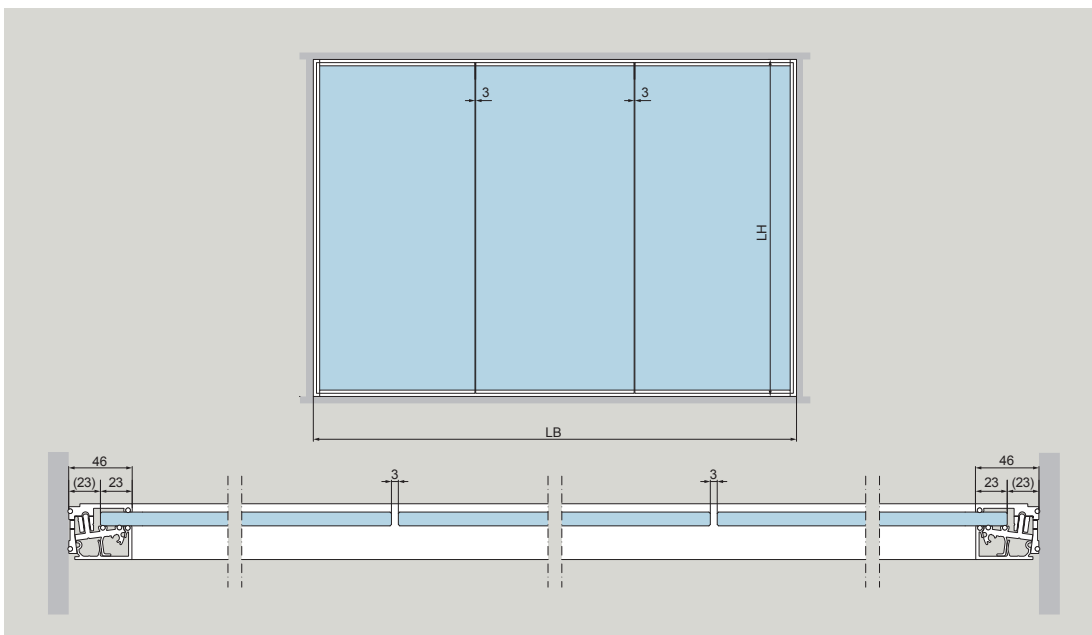
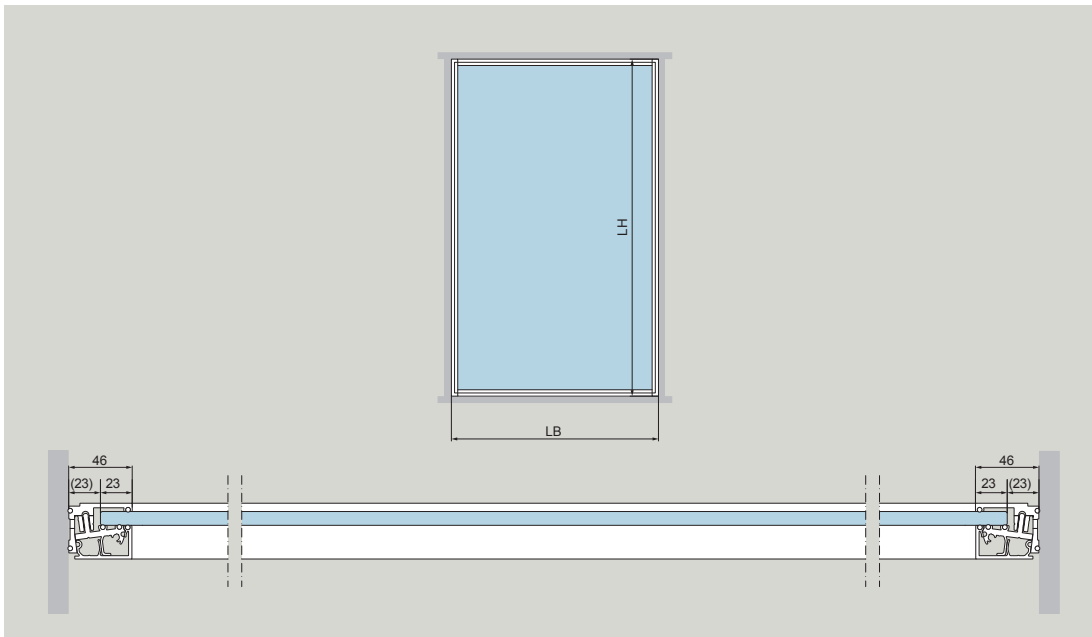

LH = Clear height  
LB = Clear width

On request, curved system configurations (only fixed elements) can also be realised, taking into account a radius of min. 1000 mm (respective profile inner edge). For curved systems (curved glass is not a regulated construction product), a proof of stability must be provided by the customer if necessary.

Functional elements on curved fixed glazing: Please contact our application technology department.

**Curved system configuration**

**Note:** A fall-proof design cannot be realized for curved installations.

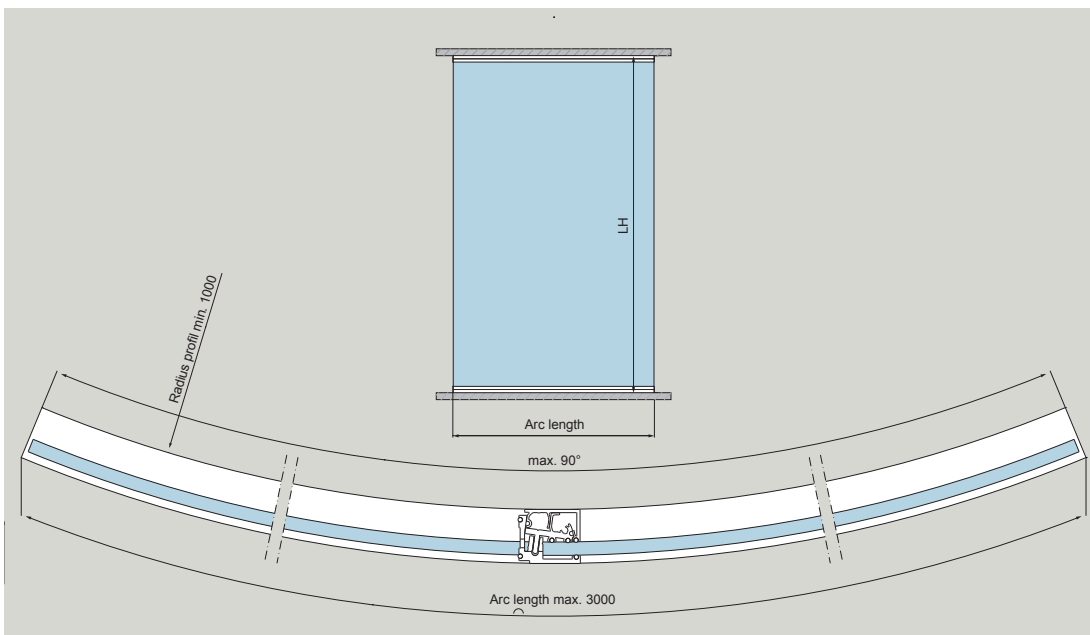
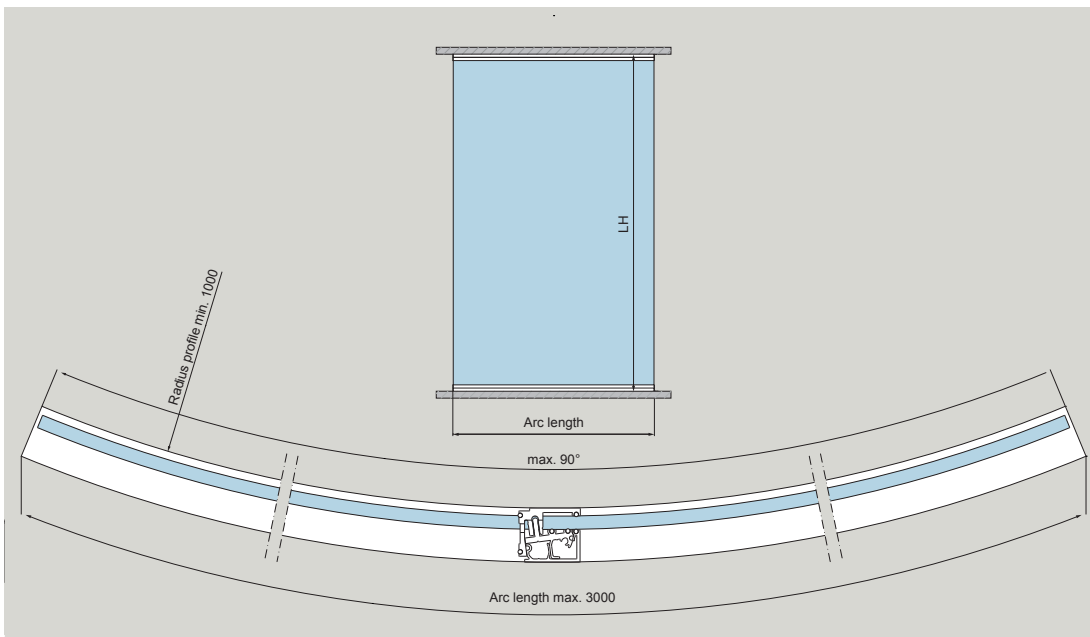

LH = Clear height

# NEW Fixed glazing technology

## Creative design options with UNIQUIN decorative bars

What was functional architecture in the past has become a trend today: The subdivision of glass surfaces with bars in interior design. This industrial look can now be created with UNIQUIN decorative bars on any glass surface. On partition walls or single doors. There are almost no limits to creativity: Uniform grids, accentuation of particular sections, graphic patterns or even just covering the glass gap between two fixed panels. The flat, powder-coated profiles are simply cut to size on site and fixed to the glass with double-sided adhesive tape. If cut edges remain visible due to the design, these can be masked with an optionally available touch-up pencil in the surface color.

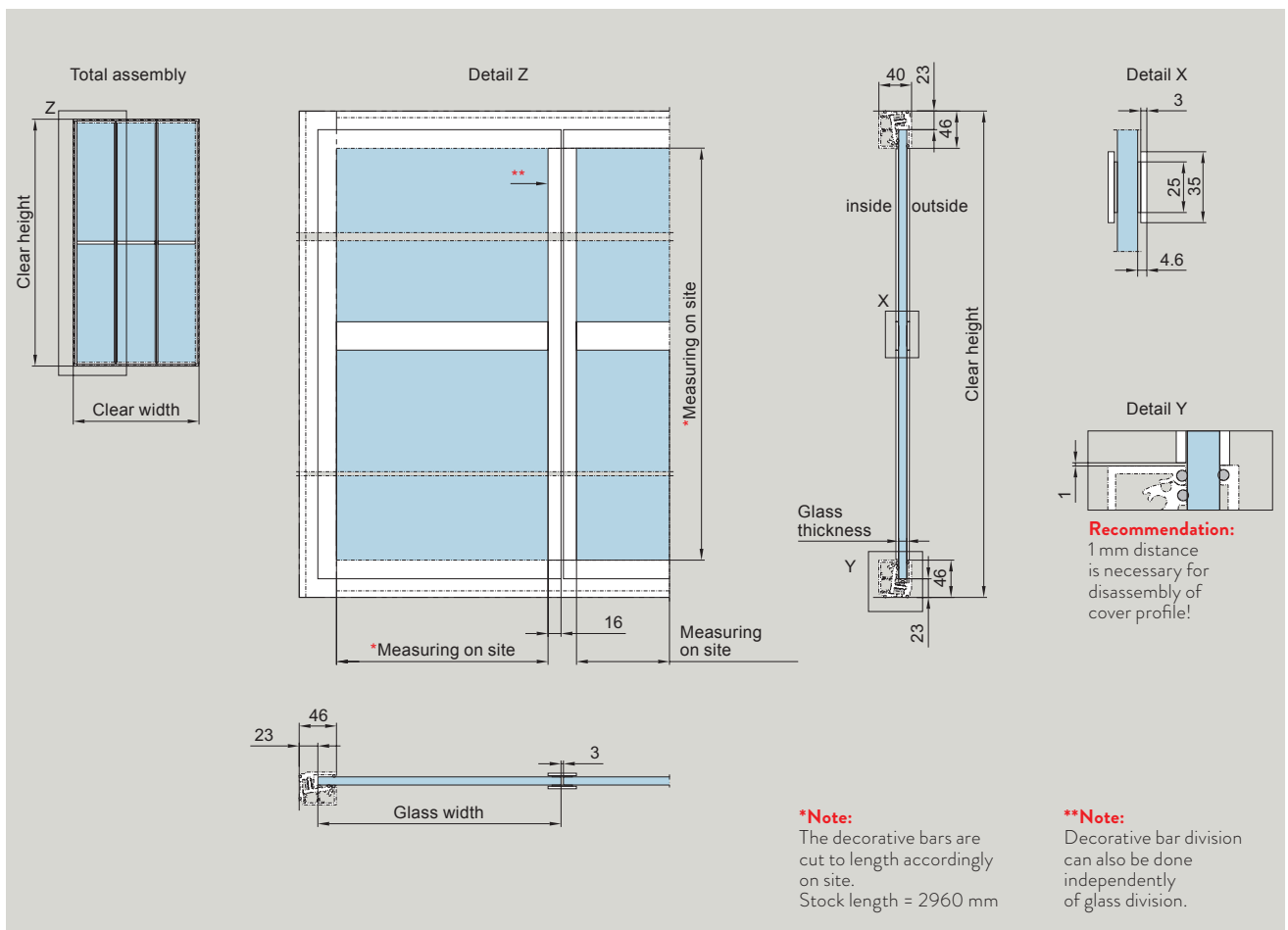

**Assembly Note:**  
For the optimum arrangement of the decorative bars, commercially available tools, such as suction lifters / guide rail sets, are recommended!

For further details see page 57.

# Space for your notes



# NEW UNIQVIN Lock 2023 MultiVar

## The new lock generation 2023

Due to the use of mortise locks according to DIN 18251, the new UNIQVIN lock design allows a multitude of extended functionalities, but also a greater variability regarding the use of handles.

Whether lock inserts with whisper latches, magnetic latches or locks with panic function - all this can be offered with the UNIQVIN lock 2023 MultiVar.

A profile cylinder lock is supplied as the standard lock insert. The lock case can be prepared for standard round rosettes with 38 mm drilling distance as well as for standard short plates. This ensures the greatest possible and variable selection.

For further details, please see page 52.

### PZ lock with roses + lever handle (free choice)

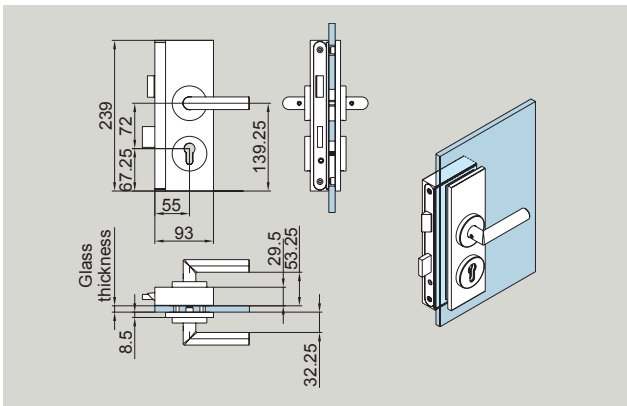

### PZ lock with short plate + lever handle (free choice)

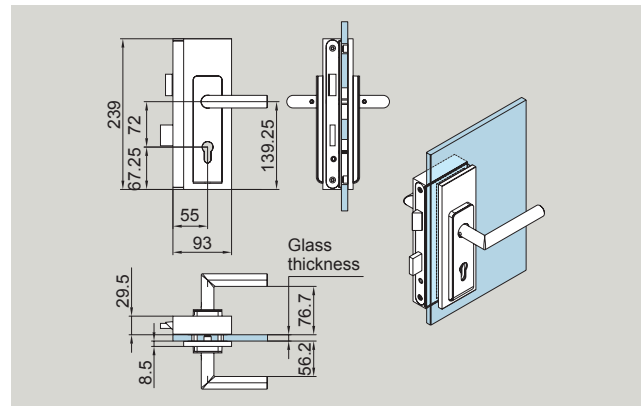

### Lock insert (PZ)

Mortise lock with whisper latch DIN L
Mortise lock with whisper latch DIN R
Mortise lock with magnetic latch DIN L / DIN R

### Mortise lock according to DIN 18251

Backset	55	Construction	Unsym.
Distance	72	Forend	stainl. steel
Forend thickness	3	UK Latch-handle centre	9.5
Forend length	235	OK Deadbolt-handle centre	37

### Detail whisper latch

A lock insert with standard whispering noise reduction. The stable whisper latch, consisting of a metal latch with partial KS coating for noise minimisation, also meets high expectations and in particular the demands of an authority.

### Detail magnetic latch

With the magnetic latch lock, the latch is set in motion magnetically. When the door is open, the latch is held in the lock by magnets. When the door is closed, however, a strong magnet pulls the latch into the strike plate. The symmetrically designed magnetic latch lock can be used for both DIN left and DIN right. All dimensions are identical to those of the standard lock.

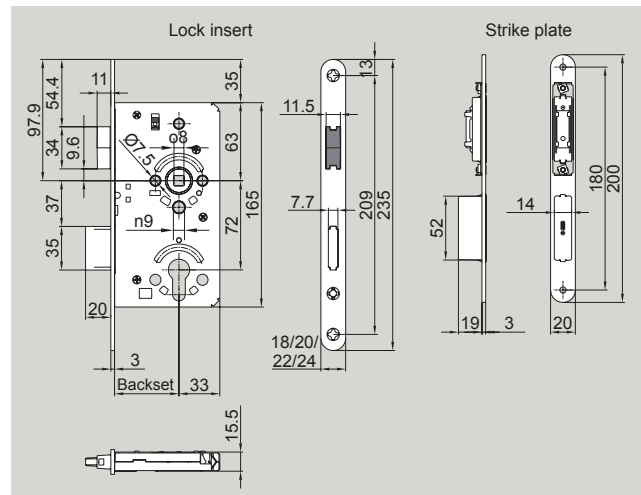
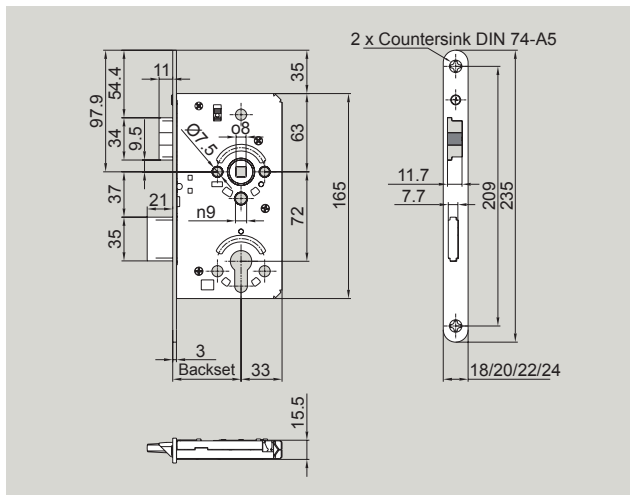

# NEW UNIQUIN hinge 2023 Clamp&Cover 80

The hinge generation 2023 is offered for door weight classes up to 80 kg and up to 130 kg. Both hinges are screwed into the inner reveal of the frames. This guarantees continuous frame cover profiles without interruption in the hinge area.

## UNIQUIN hinge 2023 Clamp&Cover 80

The UNIQUIN hinge 2023 Clamp&Cover 80 (up to 80 kg door weight) is a very small hinge, lying completely inside the rebate, invisible from the outside of the frame. Glass clamping in the hinge eliminates the need for glass preparation. Another special feature of this hinge: The glass thickness of the door can be smaller than the glass thickness of the sidelight, but never greater. Glass thickness of door: 8 - 12.76 mm  
Glass thickness of sidelight: 10 - 13.5 mm

### UNIQUIN hinge 2023 Clamp&Cover 80

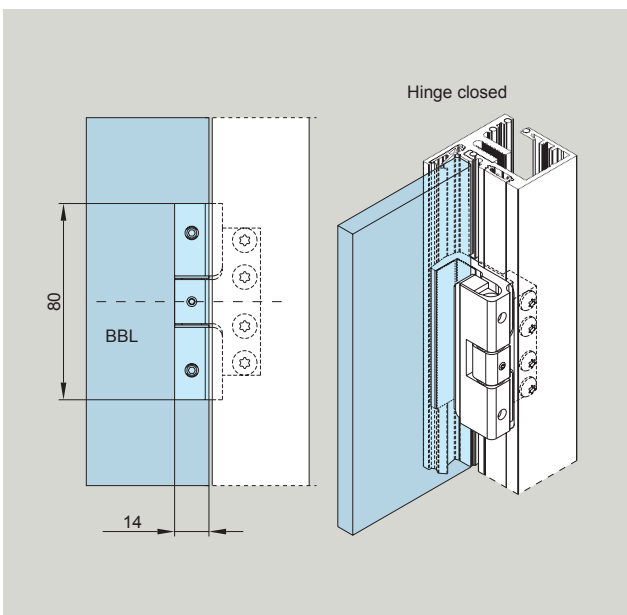

### UNIQUIN hinge 2023 Clamp&Cover 80

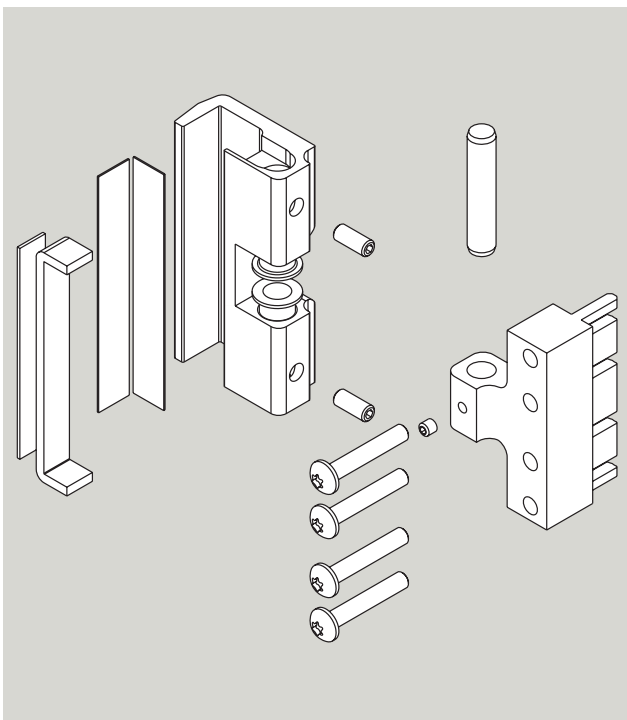
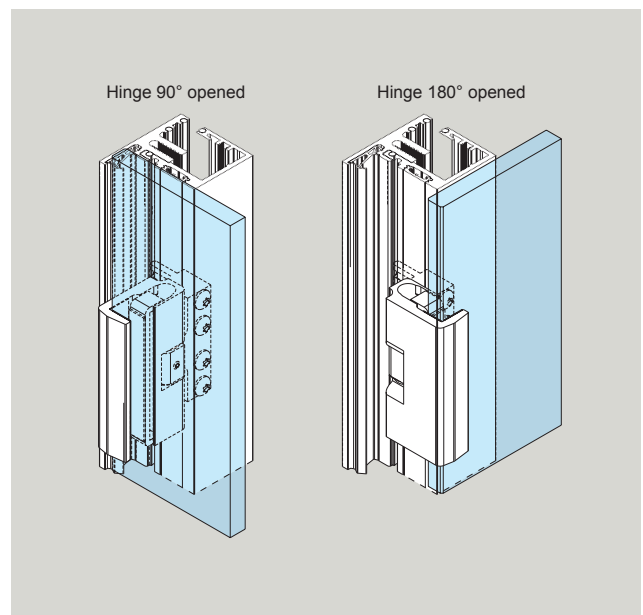

#### Technical data

Max. Door weight:  
80 kg (per pair)  
incl. all installation parts.

For ZH > 2200 mm  
3 hinges are necessary.

Glass thickness:  
8, 10 and 12 mm TSG  
10.76, 11.52 and 12.76 LSG of TSG

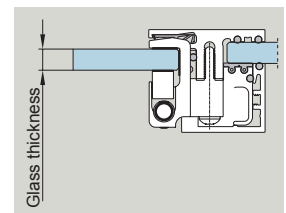

	Min. frame width (ZB)	Max. frame width (ZB)
without TS	600 mm	1186 mm
with TS 97	700 mm	1186 mm
with TS 98	800 mm	1186 mm
	Min. frame height	Max. frame height
	2000 mm	2550 mm

- TS = Door closer
- ITS = Integrated door closer
- BTS = Floor spring
- BBL = Hinge datum line

# NEW UNIQUIN hinge 2023 Standard 130

The UNIQUIN hinge 2023 Standard 130 (up to 130 kg door weight) is a size-reduced hinge. Mounting: screw clamping on 2 glass holes.

Compared to the previous model, the UNIQUIN hinge 2023 Standard 130 is an optimized solution with the same performance, but with simplified connection and installation to the frame.

It integrates inconspicuously into the system appearance. The continuous frame cover profile here also results in an attractive and straightforward design on the hinge side.

The glass preparation and hinge reference lines as well as the glass mounting remain unchanged.

## UNIQUIN hinge 2023 Standard 130

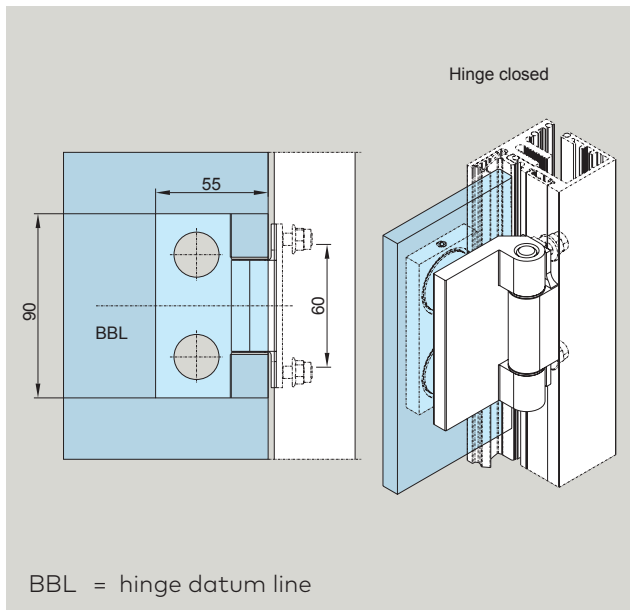

## UNIQUIN hinge 2023 Standard 130

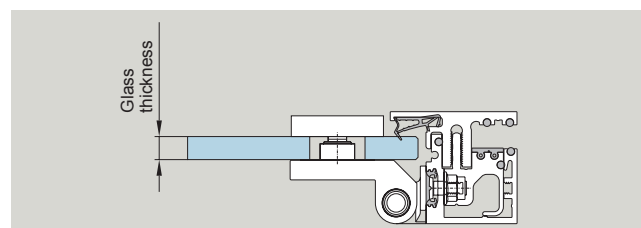
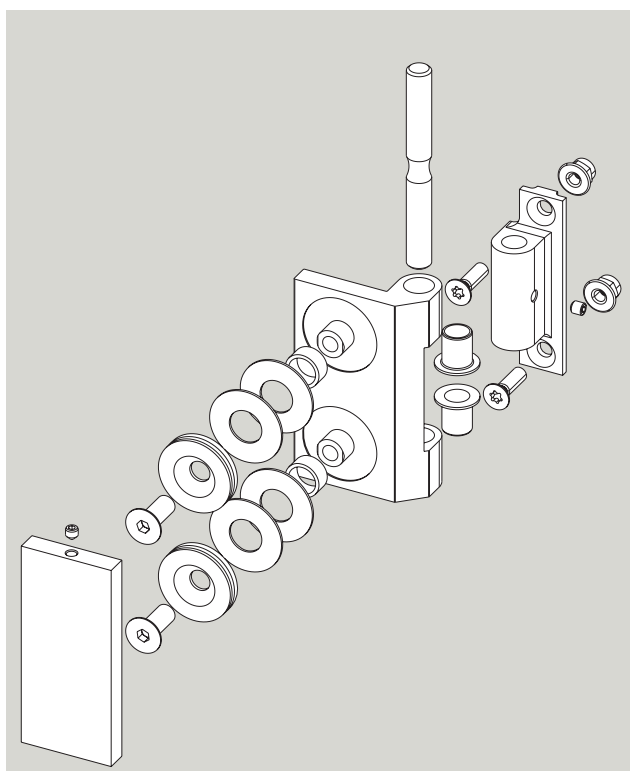
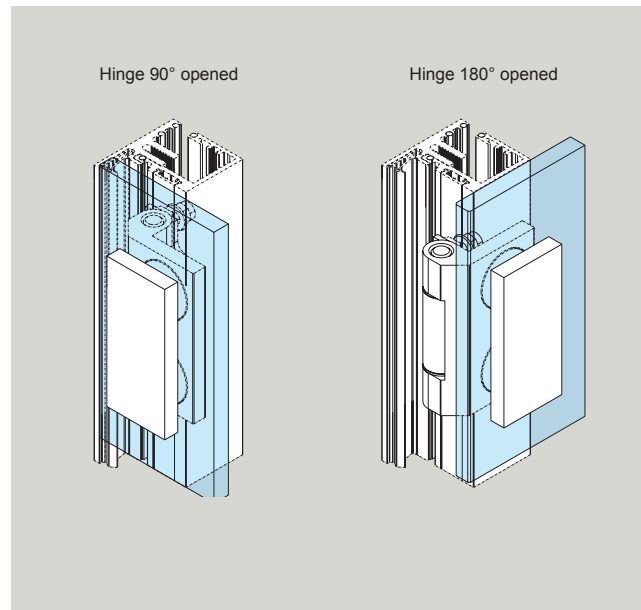

### Technical data

Max. Door weight:  
130 kg (per pair) incl. all installation parts.

For ZH > 2200 mm 3 hinges are necessary.

Glass thickness:  
10, 12, 15, 19 mm TSG  
10.76/11.52/12.76/13.52/16.76 a. 17.52 LSG of TSG

	Min. frame width (ZB)	Max. frame width (ZB)
without TS	600 mm	1410 mm
with TS 97	700 mm	1186 mm
with TS 98	800 mm	1410 mm
	Min. frame height	Max. frame height
	2000 mm	3000 mm

# UNIQUIN timber door hinges

## UNIQUIN timber door hinges

Timber door and hinges on site. The timber door and the concealed hinges listed here are components of the external timber door delivery. DORMA-Glas will

### Tectus 340

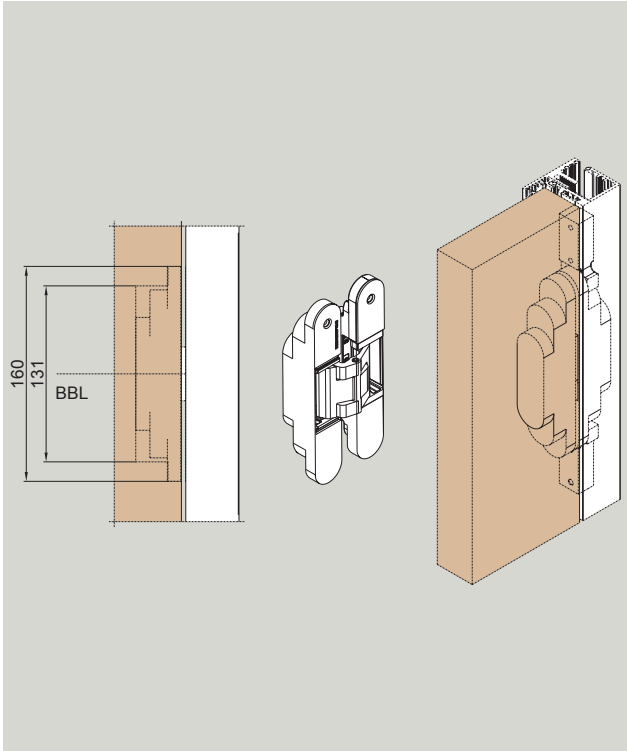

prepare the frame profile accordingly. Which model is to be used must be clarified onsite in advance. This must be specified when ordering the frame.

### Simonswerk – Tectus 340

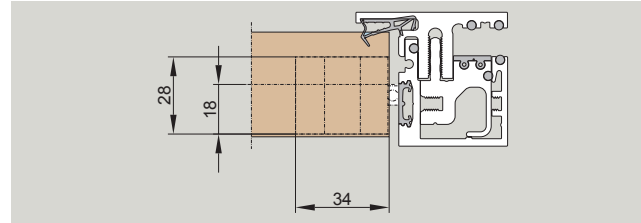

#### Technical data für Tectus und BaSys

Max. door weight:  
80 kg (per pair) incl. all installation parts.

For ZH > 2200 mm 3 hinges are necessary.

For timber doors there is a dependency between thickness of door leaf and thickness of glass side panel (page 60 resp. "The Detail" 50-010H).

Hinge reference lines according to DIN 18101:2014

	Min. frame width (ZB)	Max. frame width (ZB)
without TS	600 mm	1186 mm
with ITS 96	700 mm	1186 mm

	Min. frame height	Max. frame height
	2000 mm	3000 mm

### BaSys

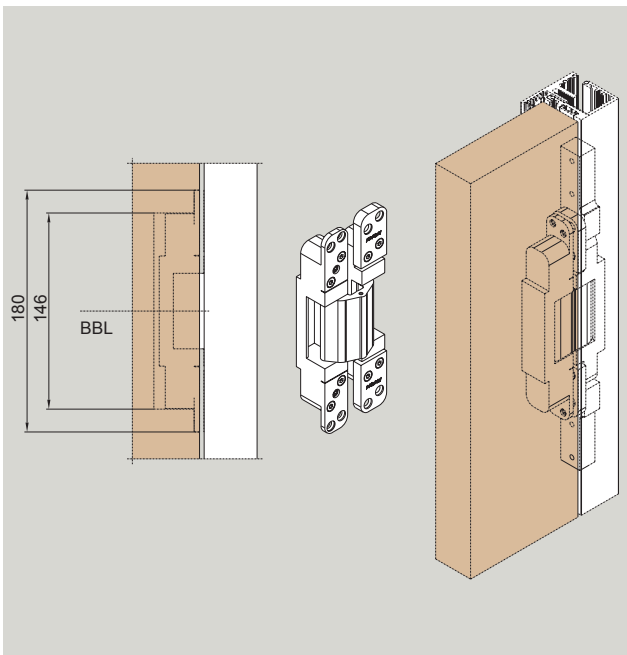

### BaSys-Band DX 100 3-D

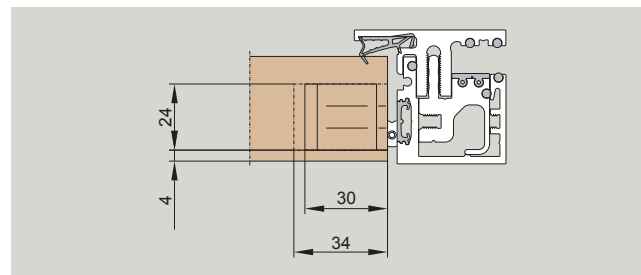

- TS = Door closer
- ITS = Integrated door closer
- BTS = Floor spring
- BBL = Hinge datum line

# UNIQUIN hinge overview

The frame dimensions depend on the additional features and combinations.

Frame size	1		2		3	
Number of hinges	2 hinges		3 hinges		3 hinges	
Frame height (ZH)	2000	2200	2201	2600	2601	3000
Frame width (ZB)	600 – 1410					

## Installation situations

in masonry	room-high	room-high with overpanel
in glass wall	room-high	room-high with overpanel

## UNIQUIN hinges

### Hinge 2023 Standard 130 for glass door up to 130 kg permissible.

UNIQUIN specific hinge spacing and glass preparation. Glass thickness depends on the thickness of the side panel.

TSG	10	12	15	19		
LSG of TSG	10.76	11.52	12.76	13.52	16.76	17.52
min. ZB - max. ZB without TS	600 – 1410					
min. ZB - max. ZB with TS97	700 – 1186					
min. ZB - max. ZB with TS98	800 – 1410					
min. ZH - max. ZH	2000 – 3000					

### Hinge 2023 Clamp&Cover 80 for glass door permissible up to 80 kg.

UNIQUIN Specific hinge spacing - Glass preparation is not required. Glass thickness is independent of side panel thickness.

TSG	8	10	12			
LSG of TSG	10.76	11.52	12.76			
min. ZB - max. ZB without TS	600 – 1186					
min. ZB - max. ZB with TS97	700 – 1186					
min. ZB - max. ZB with TS98	800 – 1186					
min. ZH - max. ZH	2000 – 2600 (with 8 mm glass max. 2200)					

### Tectus 340 / BaSys for butt-closing timber door permissible up to 80 kg.

Hinge spacing according to DIN 1801 - recess according to manufacturer's specification.

The thickness of the timber door depends on the thickness of the side panel.

Sidelight glass thickness - toughened safety glass or adapter thickness	10	12	15	19		
max. wood thickness depending on glass thickness (-0.5)	38	40	43	47		
Sidelight glass thickness LSG of TSG or adapter thickness	10.76	11.52	12.76	13.52	16.76	17.52
max. wood thickness as a function of glass thickness (-0.5)	38.5	39.5	40.5	41.5	44.5	45.5
min. ZB - max. ZB without TS	600 – 1186					
min. ZB - max. ZB with ITS96	700 – 1186					
min. ZH - max. ZH	2000 – 3000					



## Additional options with the UNIQVIN frame

### Lock

Lock case and glass preparation prepared for:	Mortise lock according to DIN 18 251-1 Distance 72 mm, backset 55 mm, flat forend 20 x 235 x 3 mm asymmetrical
---	---

### Selectable lock variants

Standard	Authority lock Series 53 class 3, with whisper latch
Option 1	Magnetic latch lock
Option 2	Panic lock according to DIN 179 with B, D or E function
Option 3	Panic lock according to DIN 1125 with B, D or E function

### Dependencies due to optional functional elements

	Description	Manufacturer	max. opening angle	max. door width	max. ZB	max. ZH
<b>Pushbar</b>		FSB	170°	1323	1410	2570
<b>Door closer</b>						
For glass doors	TS 97	dormakaba	120°	1100	1187	3000
	TS 98	dormakaba	140°	1324	1410	3000
For timber doors	ITS 96	dormakaba	120°	1100	1187	3000
<b>Drop-down seal</b> (see page 57)						
For glass doors		DORMA-Glas	140°	1210	1297	
<b>Door plate / name plate</b> (see page 57)		DORMA-Glas				
<b>E-module</b> (see page 50/51) UNIQVIN E-module pre-aligned for Gira System 55		DORMA-Glas				
<b>Strike plate</b>	Adjustable striking plate made of stainless steel Strike plate for E-opener The frame preparation as well as the postinuation of the striking plates are carried out in the factory					
<b>E-opener</b> (see page 54)						

# UNIQUIN frame sizes for glass doors

The UNIQUIN glass partition system offers three basic frame sizes that can be individually adapted in width and height. These defined basic sizes as well as the dimensions listed for them remain unchanged for all following glass door installation options, width and desired height, however, can be determined individually. Size 1 includes two hinges, whereas sizes 2 and 3 are equipped with three hinges. A drop-down seal can be

ordered optionally and without further glass preparation, or it can be retrofitted. Please note that the glass thickness of a swing door must always be equal to the thickness of the adjacent glass fixed elements (sidelights and overpanel). Exception: With UNIQUIN hinge 2023 Clamp&Cover 80, a different glass thickness can be selected for the sidelight than for the door (see pages 31/32).

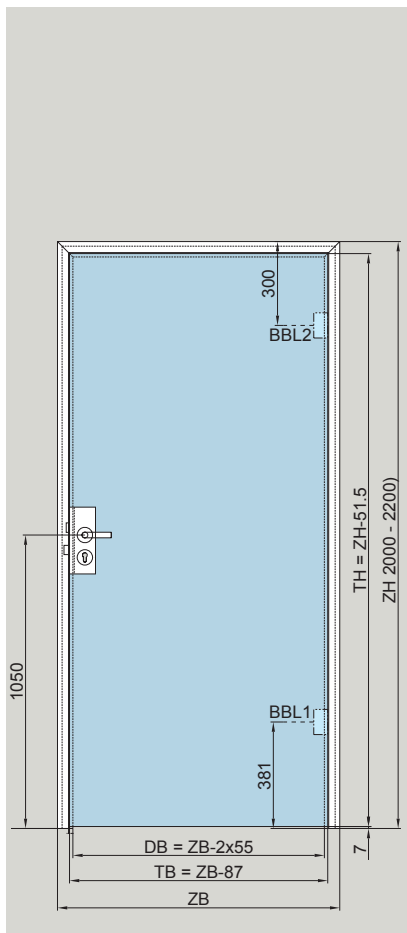

**Size 1**  
 frame height: 2000 – 2200 mm  
 frame width: 600 – 1410

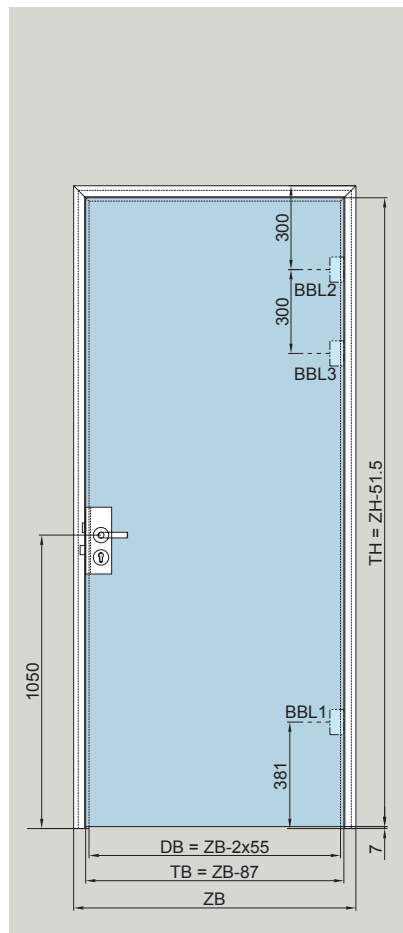

**Size 2**  
 frame height: 2201 – 2600 mm  
 frame width: 600 – 1410

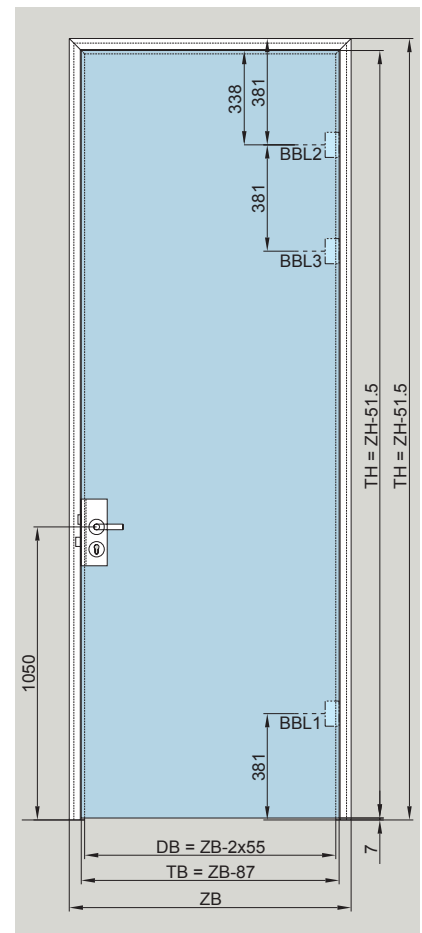

**Size 3**  
 frame height: 2601 – 3000 mm  
 frame width: 600 – 1410

**Note:** These specifications are maximum specifications. In combinations with e.g. TS, drop-down seals, etc., deviations may occur!

- TB = Door width
- TH = Door height
- ZB = Frame width
- ZH = Frame height
- DB = Passage width
- BBL = Hinge datum line

# UNIQUIN frame sizes for timber doors

Alternatively, UNIQUIN frames can also be used for full-leaf timber doors (butt-closing doors). The frame profiles are then prepared for concealed hinges. These hinge components remain components of the external timber door delivery.

The same applies to locks, handles and drop-down seals embedded in the timber door leaf. The frame is always delivered including the strike plate. The hinge and lock preparation (Manufacturer and dimension details) you can find on the pages 62/63.

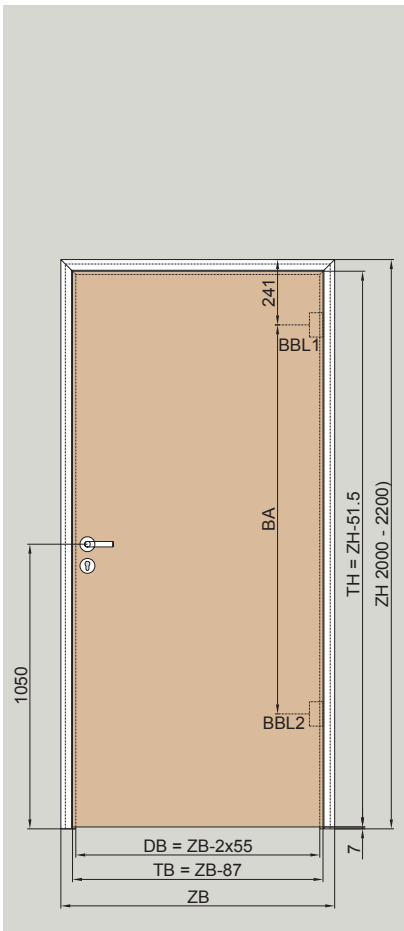

**Size 1**  
 frame height: 2000 – 2200 mm  
 frame width: 600 – 1410

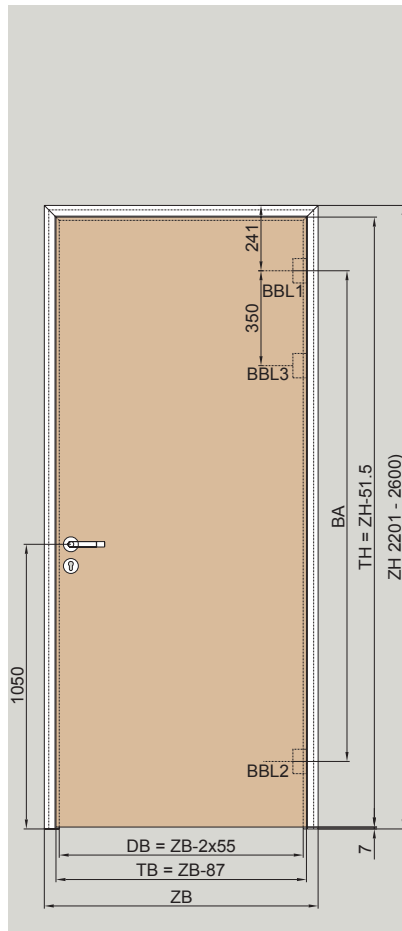

**Size 2**  
 frame height: 2201 – 2600 mm  
 frame width: 600 – 1410

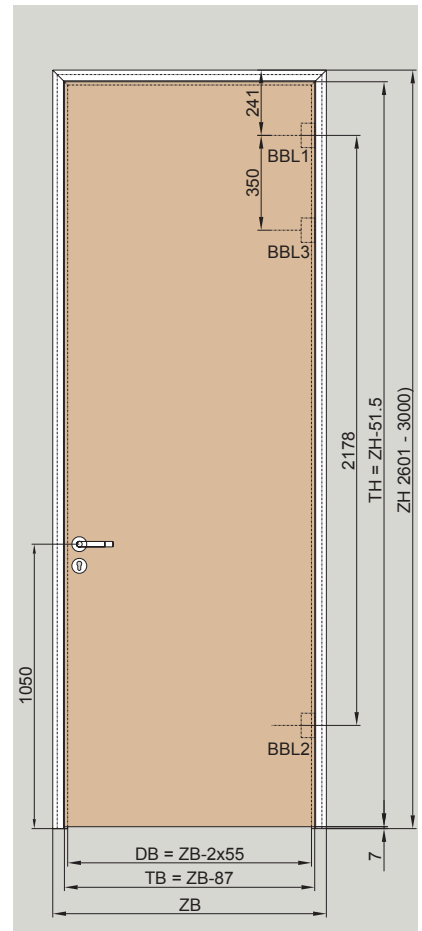

**Size 3**  
 frame height: 2601 – 3000 mm  
 frame width: 600 – 1410

**Hinge distance acc. to DIN 18101**

Frame rebate height (FMH) [mm]	Hinge distance (BA) [mm]
1796 – 1920	1310
1921 – 2045	1435
2046 – 2170	1435
2171 – 2295	1685
2296 – 2420	1810
2421 – 2545	1935
2546 – 2670	2060
2671 – 2795	2185
*2796 – 2920	2310
*2921 – 2965	2435

FMH = frame rebate height  
 \*Special dimension

- TB = Door width
- TH = Door height
- ZB = Frame width
- ZH = Frame height
- DB = Passage width
- BBL = Hinge datum line
- BA = Hinge distance

# UNIQUIN as aluminium block frame

By using the adapter profile, the UNIQUIN frame forms a complete aluminum block frame for lateral installation in the wall opening. This application, as well as the installation situation in the glass wall, offers a wide range of variants and UNIQUIN options.

## Glass (symbolic with frame, size 2)

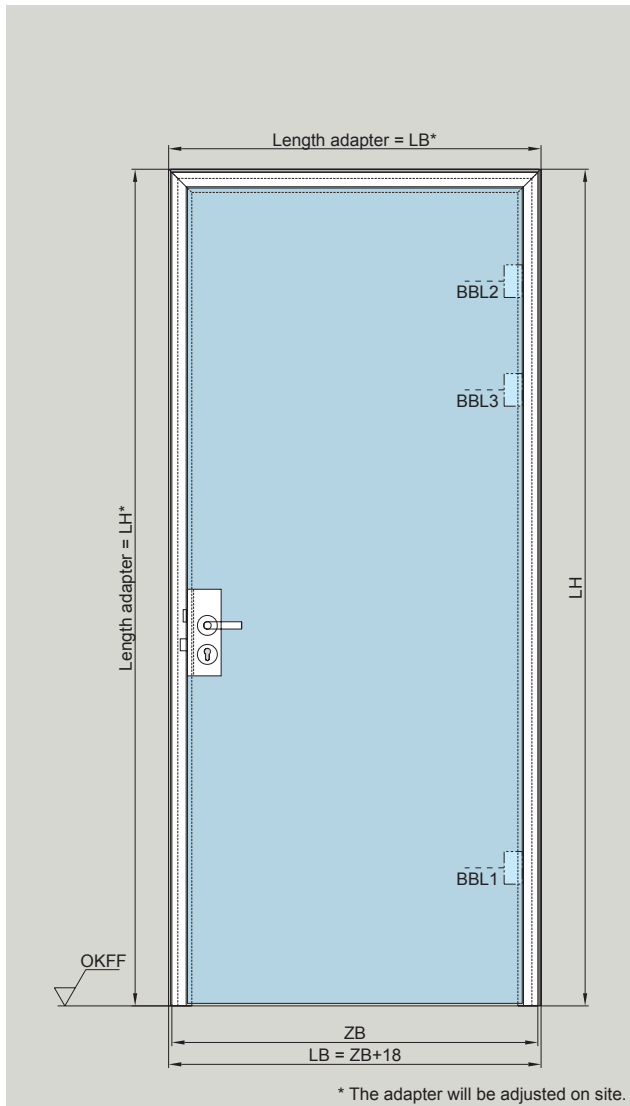

## Sectional view of glass example

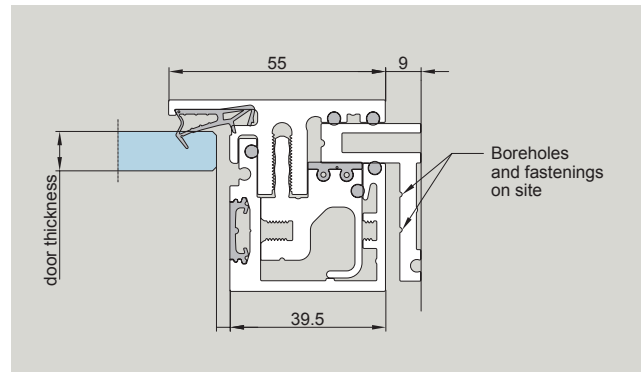

Adapter profile	Glass thickness [mm]	"The Detail" Glass door	Timber door thickness [mm]	"The Detail" Timber door
10	10	50-010B	38	50-010H1
12	12	50-010B	40	50-010H1
12.76	12.76	50-010C	40.5	50-010H2
13.52	13.52	50-010C	41.5	50-010H2
15	15	50-010C	43	50-010H2
16.76	16.76	50-010C	44.5	50-010H2
17.52	17.52	50-010B	45.5	50-010H1
19	19	50-010C	47	50-010H2

- LB = Clear width
- LH = Clear height
- ZB = Frame width
- BBL = Hinge datum line

## Sectional view glass door

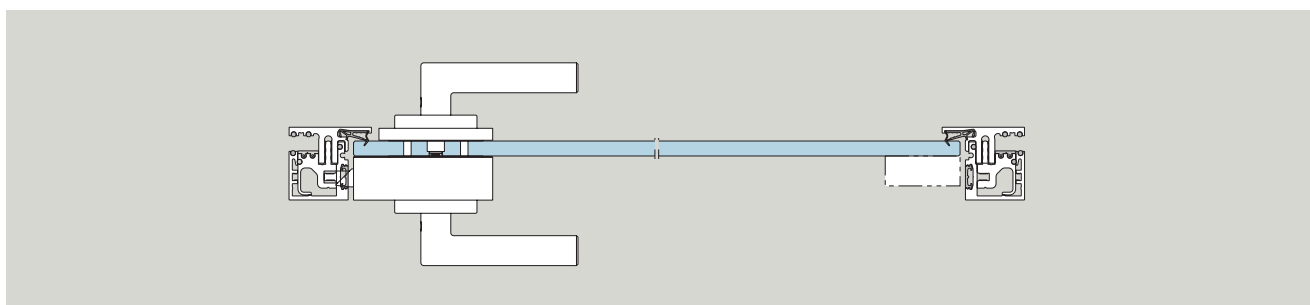

# Frame installation – revolving door in brickwork with overpanel

The combination of door and overpanel in masonry shows a variant where the base profile provides both the framing of the overpanel and the connection of the frame. Whether the door is glass or wood is irrelevant.

Please note that the glass thickness of a single-action door with the UNIQUIN hinge 2023 Standard 130 and the glass thickness of the adjacent overpanel must

always be the same. With UNIQUIN hinge 2023 Clamp&Cover 80, a different glass thickness can be selected for the sidelight and for the overpanel than for the door (see pages 31/32).

For wood door thicknesses and their dependencies on the sidelight or overpanel, please see the table listed here resp. "The Detail".

## Glass (symbolic with frame, size 2)

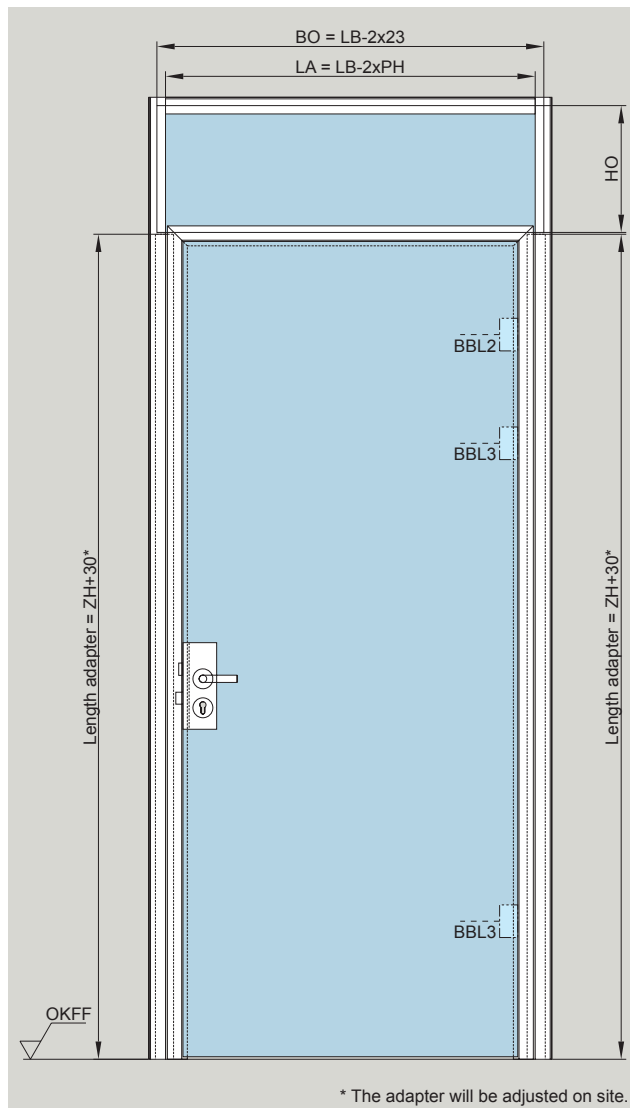

## Sectional view of glass example

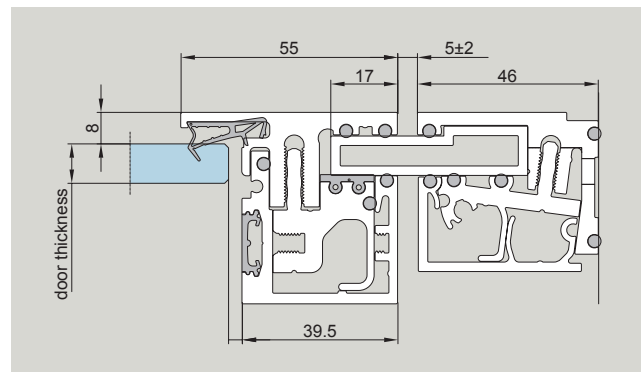

Adapter profile	Glass thickness [mm]	"The Detail" Glass door	Timber door thickness [mm]	"The Detail" Timber door
10	10	50-010B	38	50-010H1
12	12	50-010B	40	50-010H1
12.76	12.76	50-010C	40.5	50-010H2
13.52	13.52	50-010C	41.5	50-010H2
15	15	50-010C	43	50-010H2
16.76	16.76	50-010C	44.5	50-010H2
17.52	17.52	50-010B	45.5	50-010H1
19	19	50-010C	47	50-010H2

- LB = Clear width
- LH = Clear height
- ZB = Frame width
- ZH = Frame height
- BS = Sidelight width
- LA = Length mounting profile
- LA1 = Length of lower mounting profile
- BBL = Hinge datum line

## Sectional view glass door

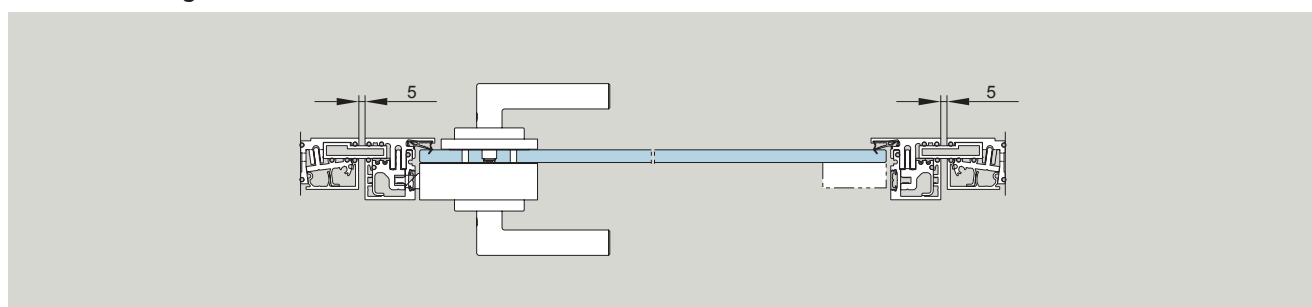



# Frame installation – single-action door with overpanel in toughened glass assemblies

Door solutions in toughened glass assemblies with overpanels can be implemented without difficulty. Here, too, you can choose between glass or timber doors.

Please note that the glass thickness of a swing door with UNIQUIN hinge 2023 Standard 130 and the glass thickness of the adjacent glass fixed elements (sidelights and overpanel) must always be the same. With UNIQUIN hinge 2023 Clamp&Cover 80, a

different glass thickness can be selected for the sidelight than for the door (see pages 31/32).

For wood door thicknesses and their dependencies on the sidelight or overpanel, please see the table listed here or "The Detail".

Systems with several doors and overpanels arranged side by side doors and overpanels require statically coordinated planning. We are happy to support you gladly.

**Glass** (symbolic with frame, size 2)

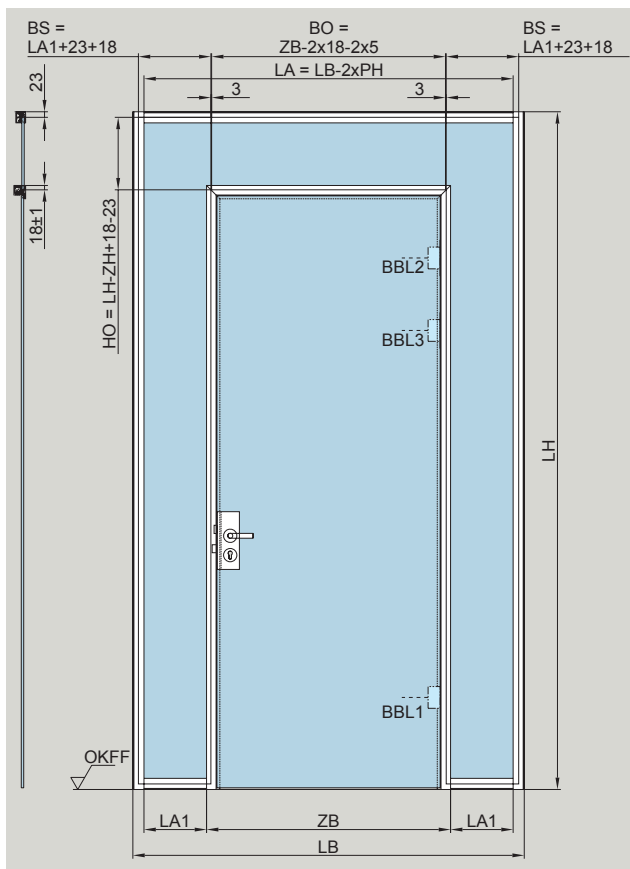

**Timber** (symbolic with frame, size 2)

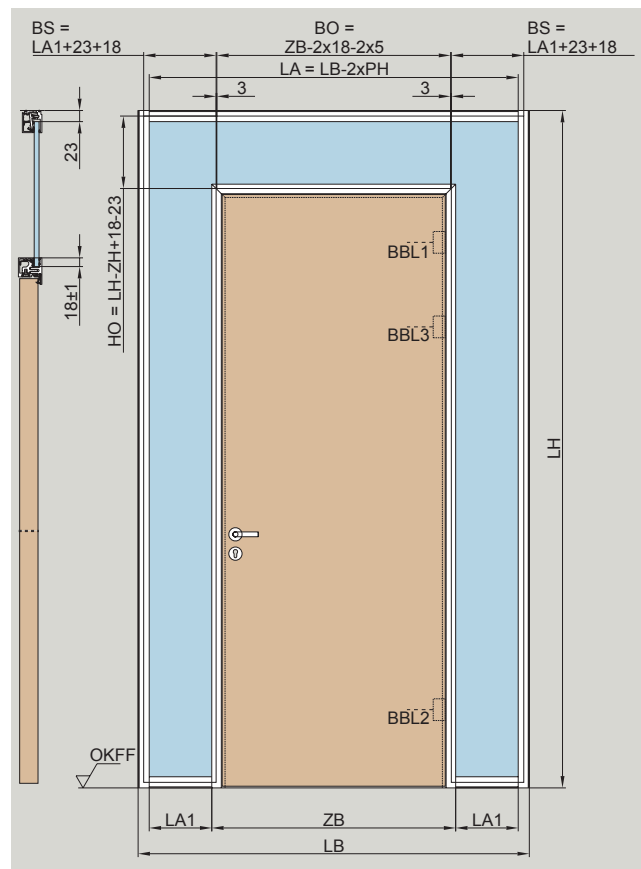

**Sectional view of glass door example**

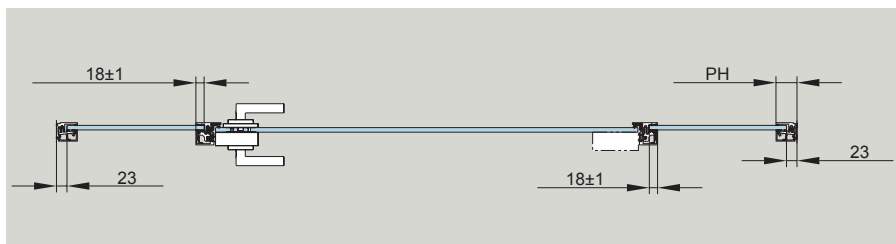

Glass thickness sidelight [mm]	Timber door thickness [mm]
10	38
10.76	38.5
11.52	39.5
12	40
12.76	40.5
13.52	41.5
15	43
16.76	44.5
17.52	45.5
19	47

- LB = Clear width
- LH = Clear height
- ZB = Frame width
- ZH = Frame height
- BO = Overpanel width
- HO = Overpanel height
- BS = Sidelight width
- LA = Length mounting profile
- LA1 = Length of lower mounting profile
- BBL = Hinge datum line
- PH = Profile height according to glass thickness

# Frame installation – double-leaf single-action door

Double-leaf hinged doors can be manufactured on request. For technical reasons, the use of a door closer and handle bars is mandatory. Locking or sound insulation requirements cannot be implemented for double-leaf doors.

Double-leaf single-action doors can also be installed in masonry. This is also possible for a double-leaf single-action door in a toughened glass system with sidelight, if the sidelights are mounted on three sides.

Max. permissible overpanel weight: 60 kg

Please note that the glass thickness of a single-action door with UNIQUIN hinge 2023 Standard 130 and the glass thickness of the adjacent glass fixed elements (sidelights and overpanel) must always be the same. With UNIQUIN hinge 2023 Clamp&Cover 80, a different glass thickness can be selected for the sidelight than for the door (see pages 31/32).

**Glass** (symbolic with frame, size 2)

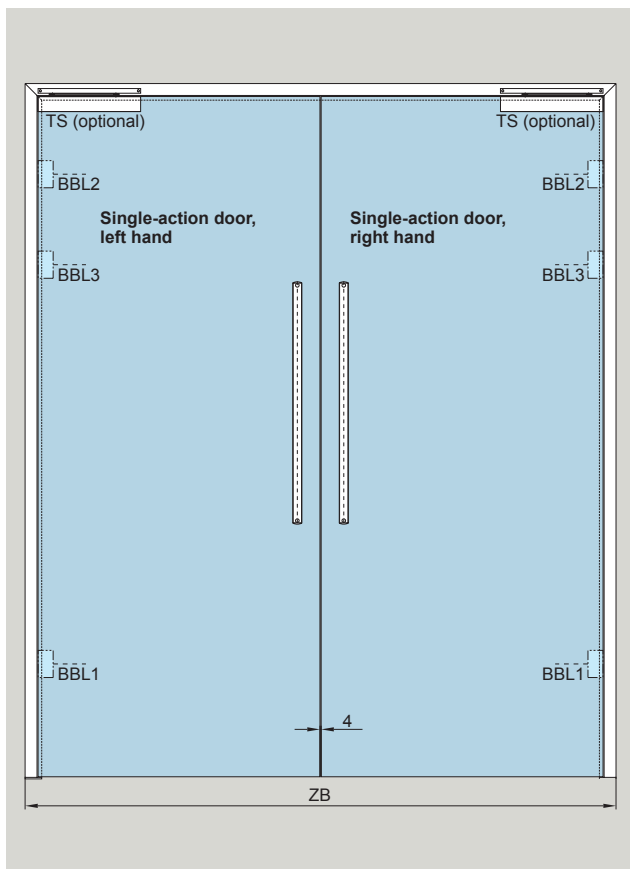

**Timber** (symbolic with frame, size 2)

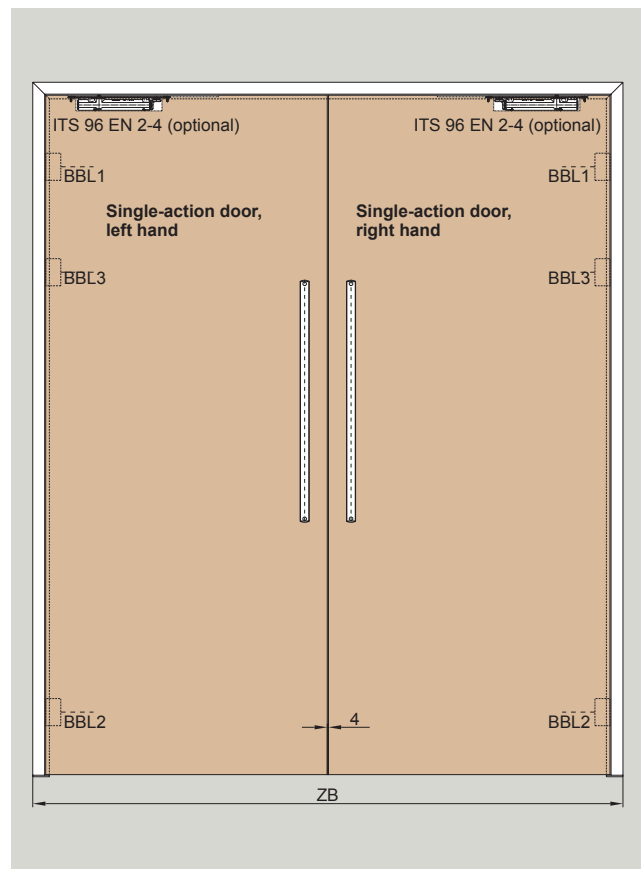

**Sectional view of glass door example**

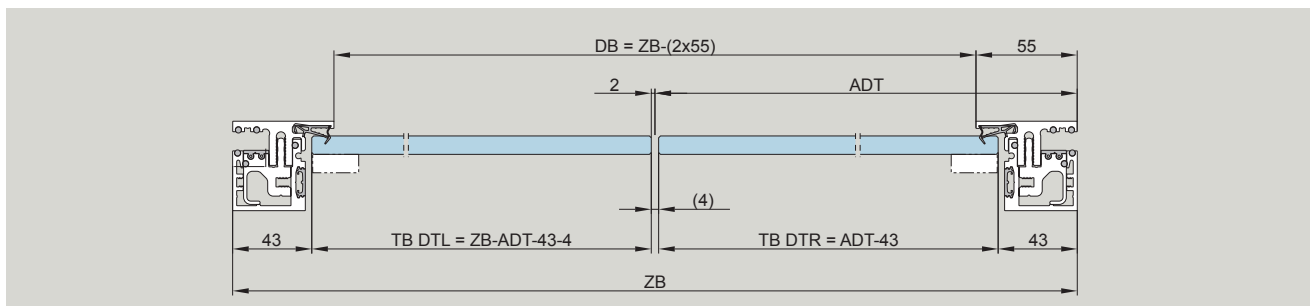

- TB = Door width
- ZB = Frame width
- DB = Passage width
- BBL = Hinge datum line
- ADT = Outer dimension pivoting door

# NEW UNIQUIN 2023 door closer

The adoption of dormakaba TS 97, which has now been extended to include the dormakaba TS 98 with the new hinge generation, is a harmonious addition in terms of design and dimensions. The use of its technological advantages offers further added value.

Now it is possible to use both TS 97 and TS 98 with both hinges for glass doors. Pre-assembled frames for timber doors are still supplied prepared for dormakaba ITS 96 if required.

## Hinges with TS 97

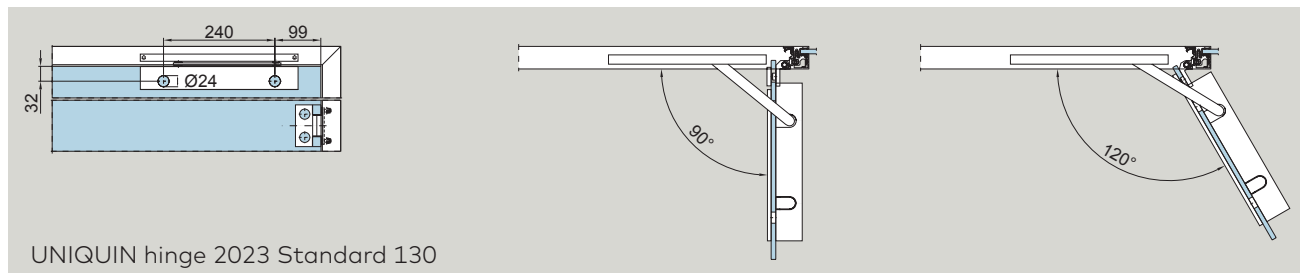

UNIQUIN hinge 2023 Standard 130

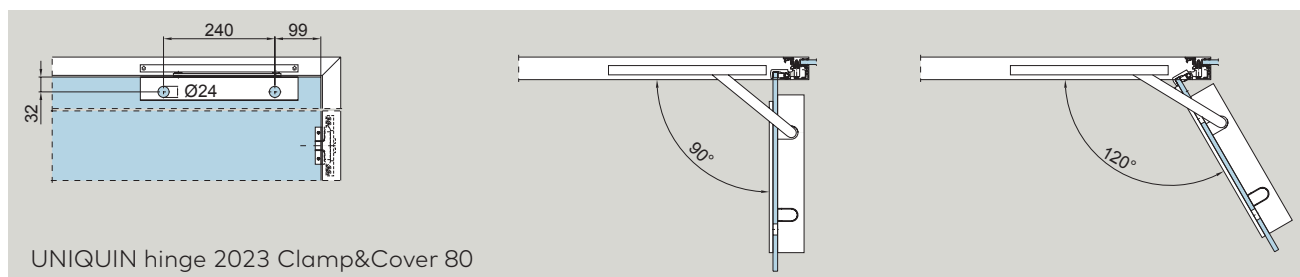

UNIQUIN hinge 2023 Clamp&Cover 80

## Hinges with TS 98

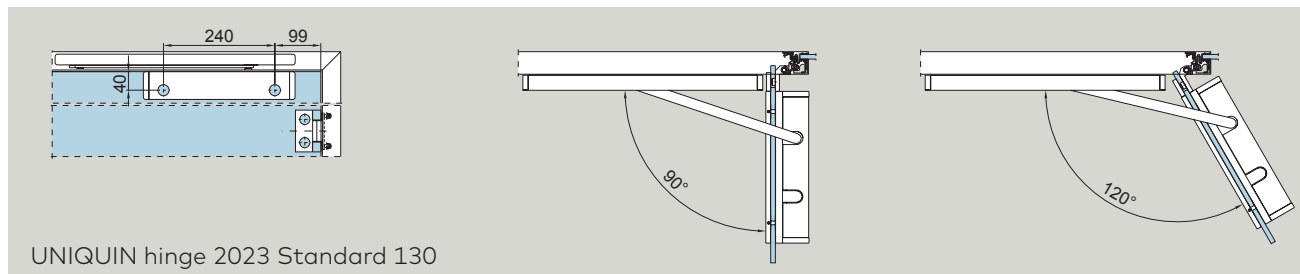

UNIQUIN hinge 2023 Standard 130

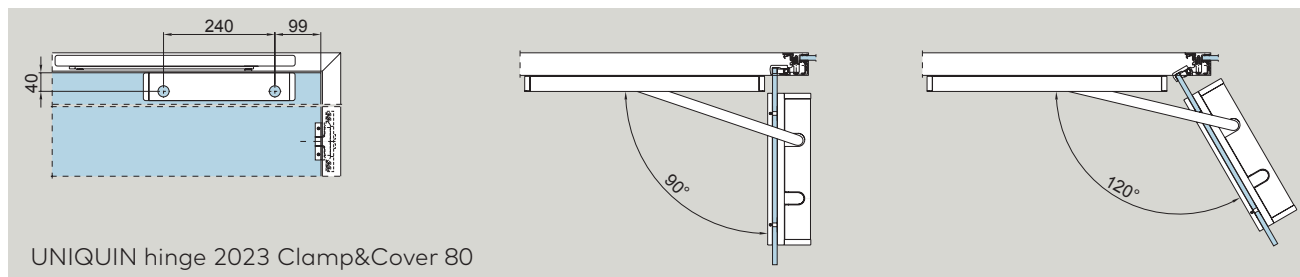

UNIQUIN hinge 2023 Clamp&Cover 80

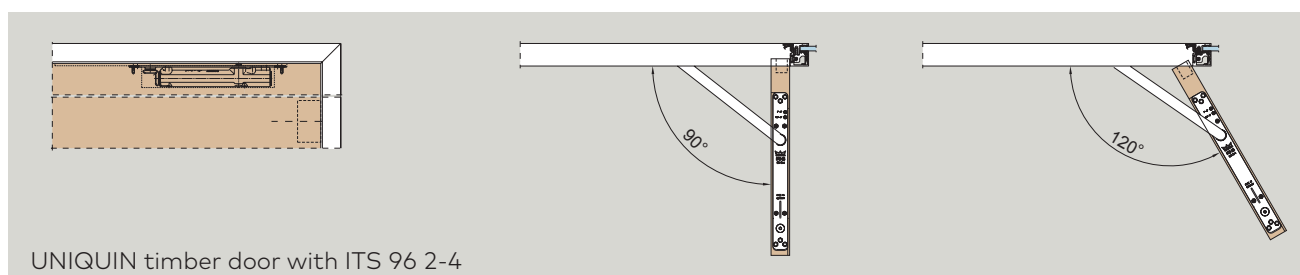

UNIQUIN timber door with ITS 96 2-4

# Space for your notes

# Single-leaf glass sliding door in toughened glass assembly

MUTO Comfort L 80 DORMOTION (single-leaf, double-leaf or synchro variant) is used as a sliding door system on glass. The track rail profile is mounted on the outside of the toughened glass assembly with overpanel and fixed sidelight (against the hinge side of a frame application). A fixed panel is required on the respective handle side. Regardless of the fixed panels, the glass thickness of the sliding door is 8 – 13.52 mm.

The system is pre-assembled as standard, the rail is delivered already drilled. Optional accessories, such as an integrated locking device (battery-operated or cable systems), LSG accessories, etc. can also be configured. Other MUTO systems on request.

**Note:** When using the DORMOTION unit, we recommend installing a UNIQUIN pull handle. Following consultation with our application technology team, the MUTO Comfort Self-Closing sliding door system can also be used.

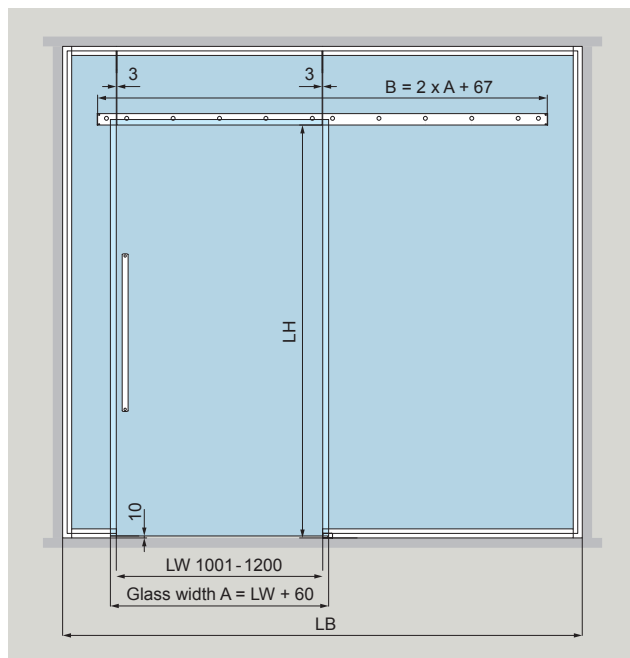

## MUTO L 80 sliding door in UNIQUIN

Max. leaf width: 1500 mm  
 Min. leaf width: 660 mm  
 Max. leaf height: 3000 mm  
 Max. leaf weight: 80 kg

## UNIQUIN overpanel

Max. width: 1434 mm  
 Max. height: 1000 mm  
 Max. weight: 80 kg

B = Track rail length  
 A = Leaf width  
 LH = Clear height  
 LW = Clear passage width  
 LB = Clear width

### Example:

LW from 1001 to 1200 mm

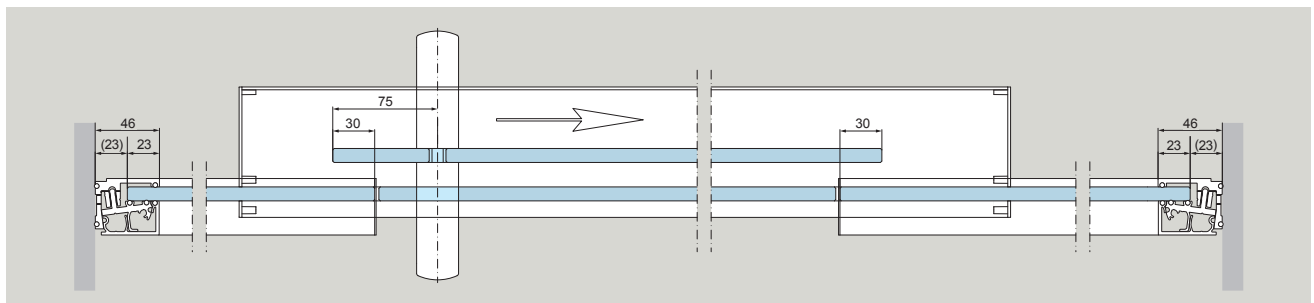

The sliding wing is installed against the clip profile side.

For glass preparation and further sliding door sizes, please refer to page 60

More information can be found in our technical brochure on sliding door fittings.



# Single-leaf timber sliding door in toughened glass assembly

MUTO sliding door systems can be implemented with a timber leaf instead of a glass leaf. A separate timber adapter is used for this purpose. Regardless of the fixed panels, the timber thickness of the sliding door is 28 – 50 mm.

**Note:** When using the DORMOTION unit, we recommend installing a UNIQUIN pull handle. Following consultation with our application technology team, the MUTO Comfort Self-Closing sliding door system can also be used.

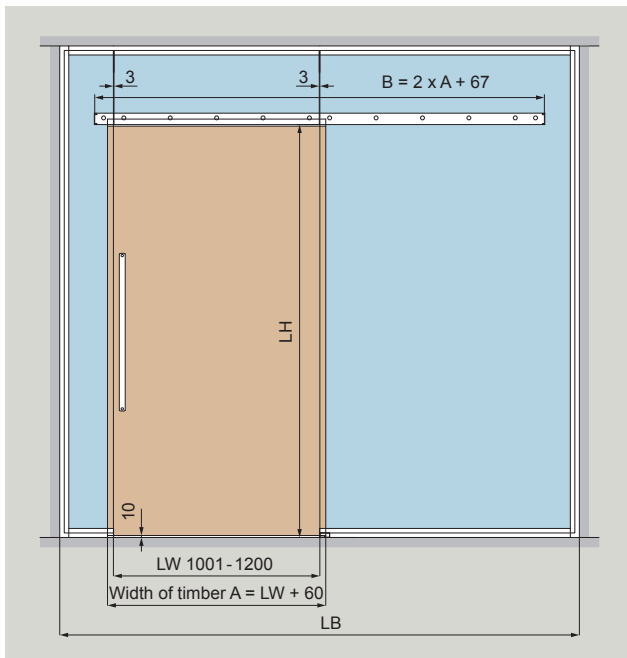

## MUTO L 80 sliding door in UNIQUIN

Max. leaf width: 1500 mm  
 Min. leaf width: 660 mm  
 Max. leaf height: 3000 mm  
 Max. leaf weight: 80 kg

## UNIQUIN overpanel

Max. width: 1434 mm  
 Max. height: 1000 mm  
 Max. weight: 80 kg

B = Track rail length  
 A = Leaf width  
 LH = Clear height  
 LW = Clear passage width  
 LB = Clear width

### Example:

LW from 1001 to 1200 mm

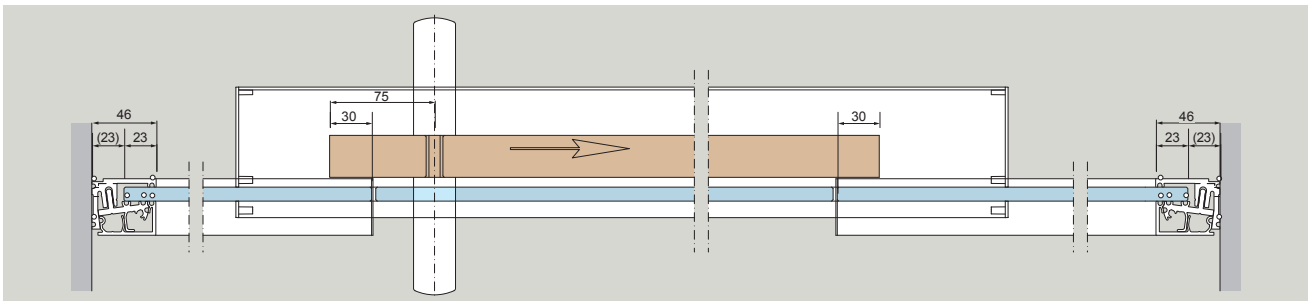

The sliding wing is installed against the clip profile side.

# Double-leaf glass sliding door in toughened glass assembly

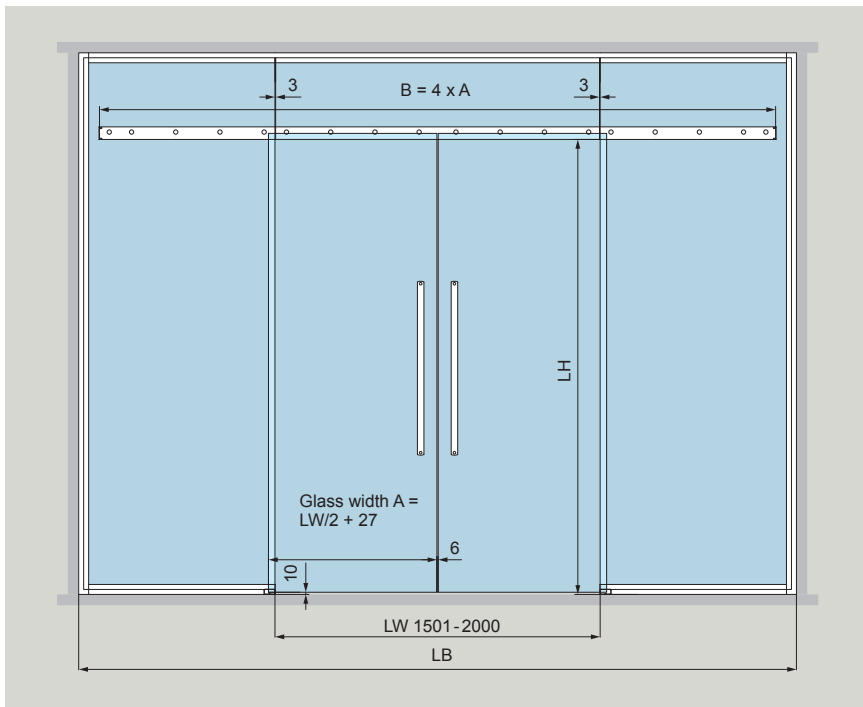

**MUTO L 80 sliding door  
(double-leaf) in UNIQUIN**

- Max. leaf width: 2 x 1027 mm
- Min. leaf width: 2 x 660 mm
- Max. leaf height: 3000 mm
- Max. leaf weight: 80 kg

**UNIQUIN overpanel**

- Max. width: 1994 mm
- Max. height: 1000 mm
- Max. weight: 40 kg

**Example:**

LW from 1501 to 2000 mm

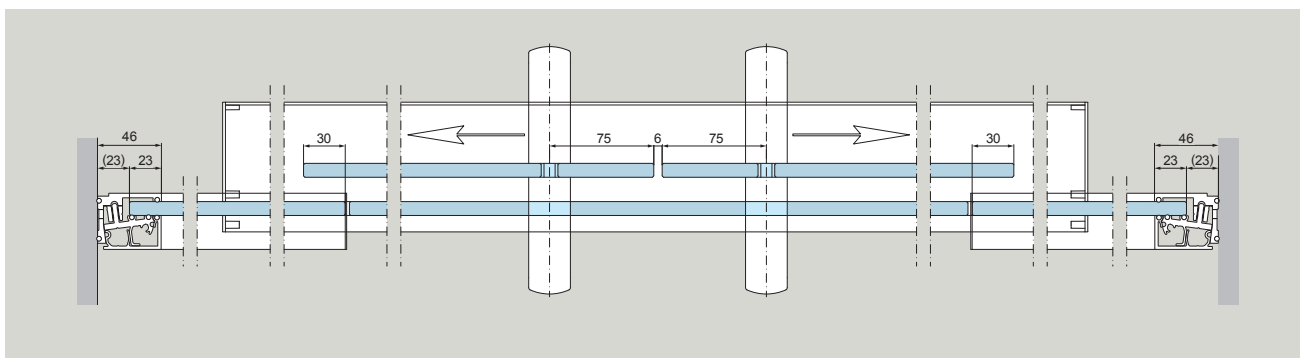

For glass preparation and further sliding door sizes, please refer to page 60.

- B = Track rail length
- A = Leaf width
- LH = Clear height
- LW = Clear passage width
- LB = Clear width

# Double-leaf timber sliding door in toughened glass assembly

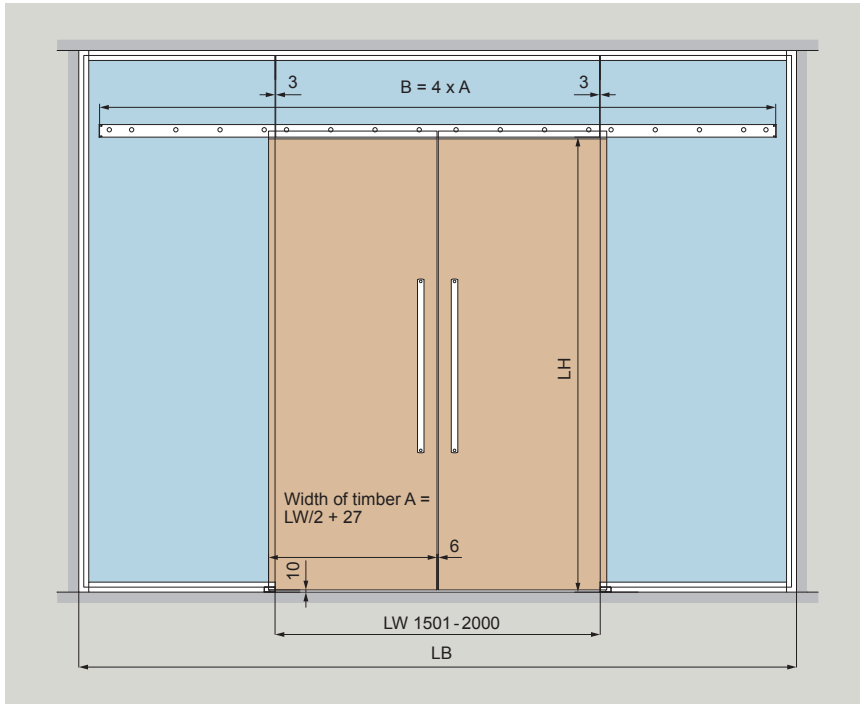

**MUTO L 80 sliding door  
(double-leaf) in UNIQUIN**

- Max. leaf width: 2 x 1027 mm
- Min. leaf width: 2 x 660 mm
- Max. leaf height: 3000 mm
- Max. leaf weight: 80 kg

**UNIQUIN overpanel**

- Max. width: 1994 mm
- Max. height: 1000 mm
- Max. weight: 40 kg

**Example:**

LW from 1501 to 2000 mm

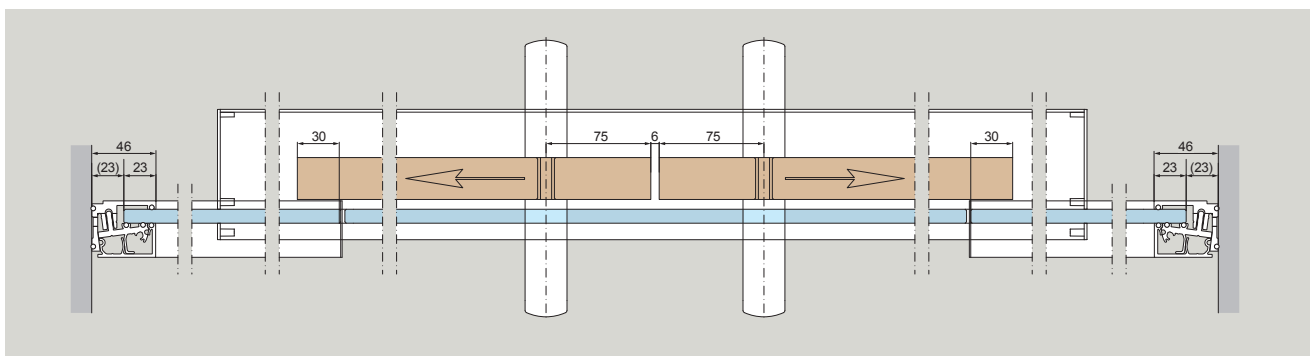

- B = Track rail length
- A = Leaf width
- LH = Clear height
- LW = Clear passage width
- LB = Clear width

## Acoustic module

UNIQWIN acoustic modules reduce sound reflection and thus optimise room acoustics. They are also an attractive design element. An acoustic module consists of an aluminium frame which is covered with acoustic convoluted foam for sound absorption (optional or on site) as well as with a glass insert for enhanced sound protection. The glass also serves as an entry barrier. The convoluted foam side (for sound absorption) is covered with a printable stretch fabric made of a special material (acoustic image). The other side can be provided with a stretch fabric made of a material of your choice (advertising image). Both fabrics can be printed with motifs or advertising messages and attached directly to the aluminium frame by flat welding. Fabrics to be procured by the customer.



### Specification note on acoustic or advertising image

For a pleasant sensation of reverberation as well as for sound absorption, we recommend using a suitable fabric, e.g. textile Trevira CS 300 g/m<sup>2</sup> (in conjunction with the convoluted foam) for the acoustic image. For the advertising image on the back, no specifications regarding the material need to be observed. Circumferential flat welding for frame: 15 x 2.8 mm per image.

The use of LED panels for lighting or the installation of other devices (e.g. a TV) is possible (for installation dimensions see technical document "The Detail" 50-040/50-040A/50-041). LEDs or other accessories are an option. The procurement and installation must be carried out by the customer.

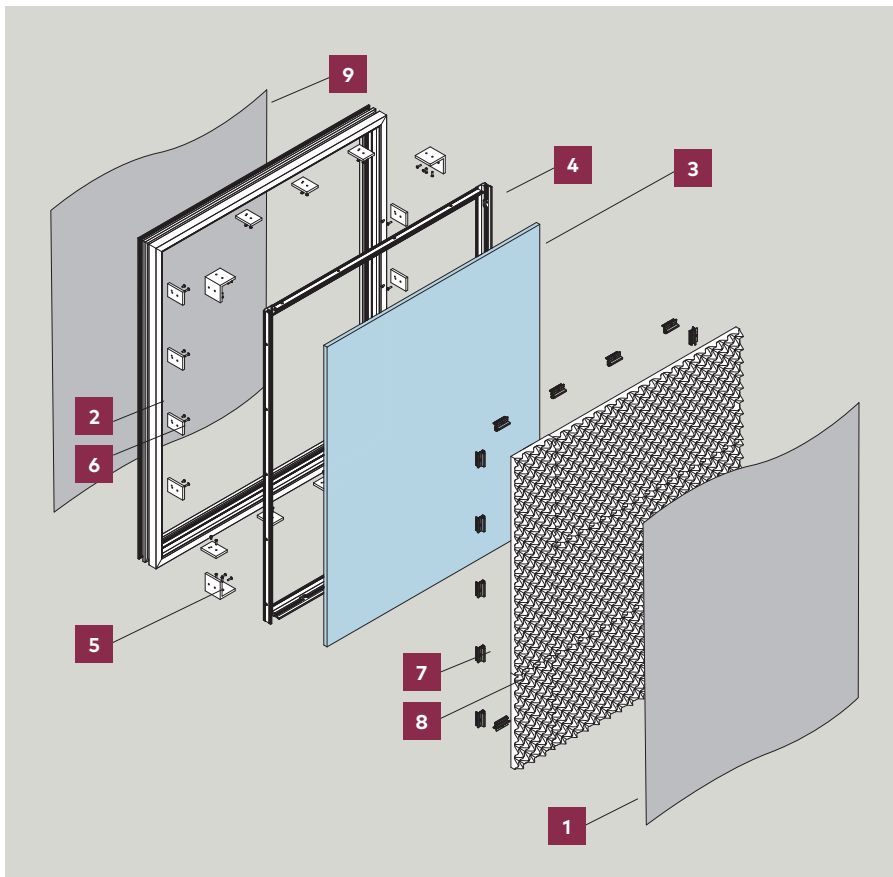

- 1 Fabric (advertising image)
- 2 Acoustic / advertising frame cross section
- 3 Glass (noise protection, entry barrier)
- 4 Base profile fixed element
- 5 Angle connectors
- 6 Spacer
- 7 Clamping piece
- 8 Acoustic convoluted foam 1000 x 500 mm (can optionally be ordered or procured by customer)
- 9 Fabric (acoustic image)

# Structure of acoustic/advertising image frames

**With glass overpanel** Max. width: 1200 mm  
 Min. width: 300 mm  
 Max. height: 2200 mm  
 Min. height: 300 mm

**In full system height** Max. width: 1200 mm  
 Min. width: 300 mm  
 Max. height: 4000 mm  
 Min. height: 300 mm

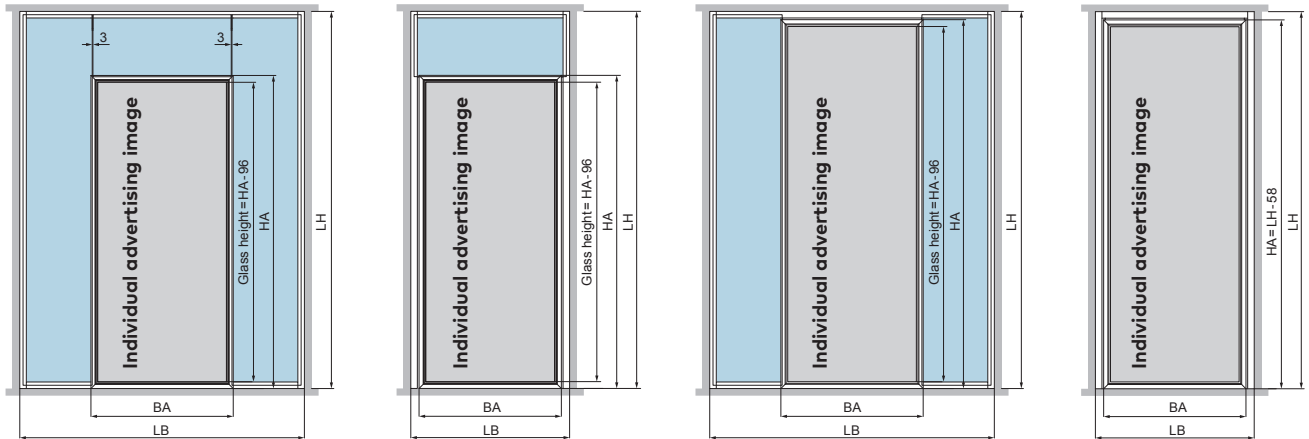

Max.glass thickness: 17.52 mm

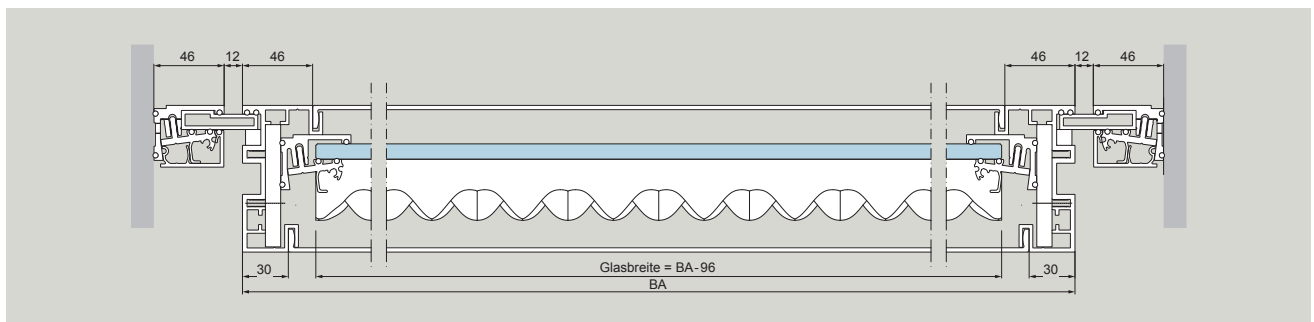
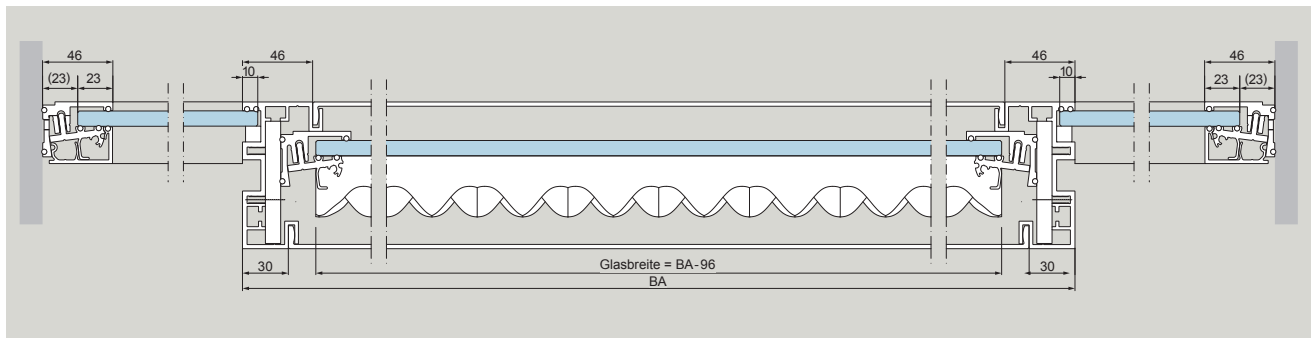

- HA = Height acoustic module
- BA = Hinge distance
- LB = Clear width
- LH = Clear height

# Electrification

When planning buildings and premises, there is often a lack of power sources and switches. This is not a problem when designing a room with UNIQWIN. The electrics can be retrofitted and adapted individually

by installing a UNIQWIN electric module as part of the UNIQWIN partition wall system.

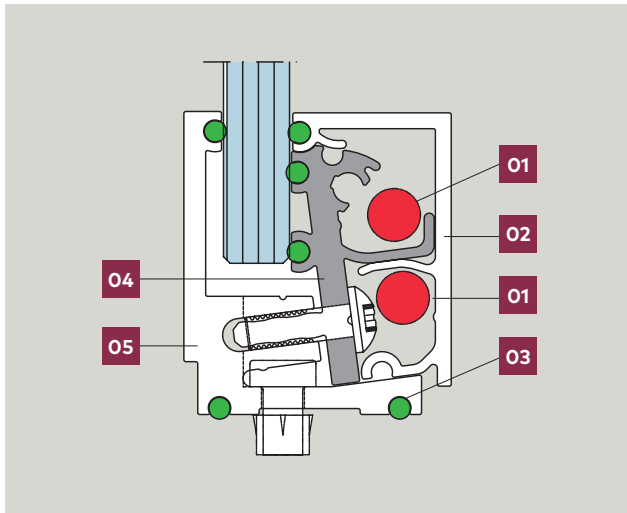

Figure 1

## Wiring in the base profile:

The UNIQWIN base profile is suitable for electrification. A maximum of two 3-wire NYM cables  $3 \times 1.5 \text{ mm}^2$  can be inserted into the profile. As shown in Figure 1, one cable is placed in the glass clamp and another cable fixed in the cover profile by cable holders. The cable holders are positioned between two glass clamps.

1. NYM cable  $3 \times 1.5 \text{ mm}^2$
2. Cover profile
3. Silicone welt (dark grey)
4. Glass clamp
5. Base profile

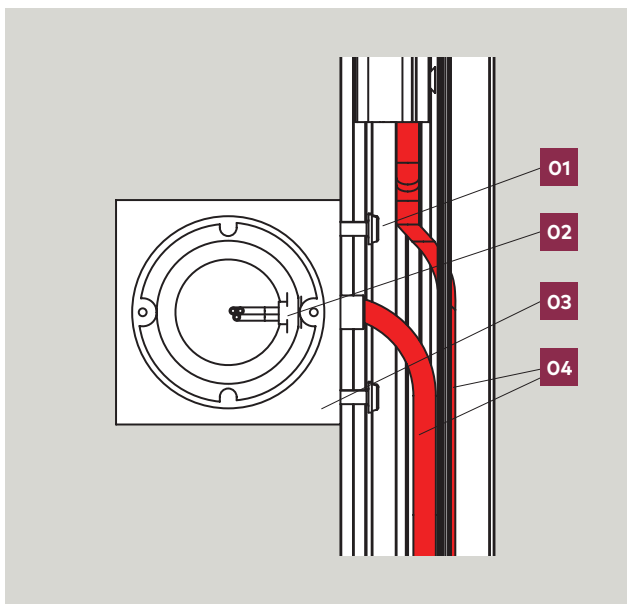

Figure 2

## Wiring to the E-module:

The E-module is an aluminium element with an integrated standard flush-mounted socket (hollow wall socket) for accommodating standardised switch systems. It is designed for Gira System 55 etc. and can be used for over 300 functions (see Gira portfolio). The integrated strain relief ensures secure mounting and dismantling of the cover profile of the frame.

1. M5 connecting screw
2. Strain relief
3. E-module (designed for Gira System 55)
4. NYM cable  $3 \times 1.5 \text{ mm}^2$

**Wiring in the system:**

Continuous wiring of the system is possible. This also applies to the cable feed-through of a frame element (from hinge generation 2023).

**Please note:**

- Assembly is carried out on site.
- Electrification may only be carried out by qualified personnel.
- The bending radius must be observed when connecting cables (see cable manufacturer's specifications).
- Sharp edges, the clamping piece of the frame and any recesses that may come into contact with the cable must be deburred on site.
- The cable must only be inserted into the E-module with a double sheath.

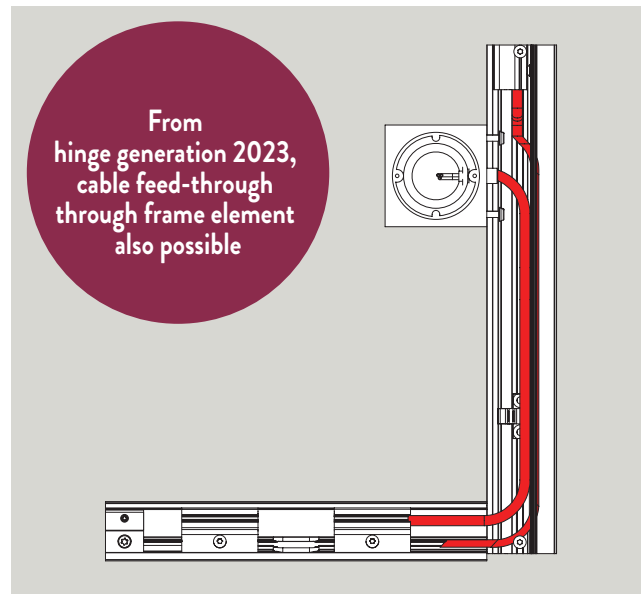

**Continuous cabling of the system possible. Even with cable feed-through of a frame element!**

**01** Electrical module on the strike plate side of the frame profile, e.g. for a light switch

**02** Electrical module on the strike plate side of the frame profile, e.g. for a safety wall socket

**03** Frame side of the hinge suspension is alternatively for the cable routing suitable

**04** Cable routing in mounting profile

**05** Service connection

**06** Double cable routing from mounting profile to the frame profile to the first E-module possible

**07** A return or supply line from the belt side is also possible

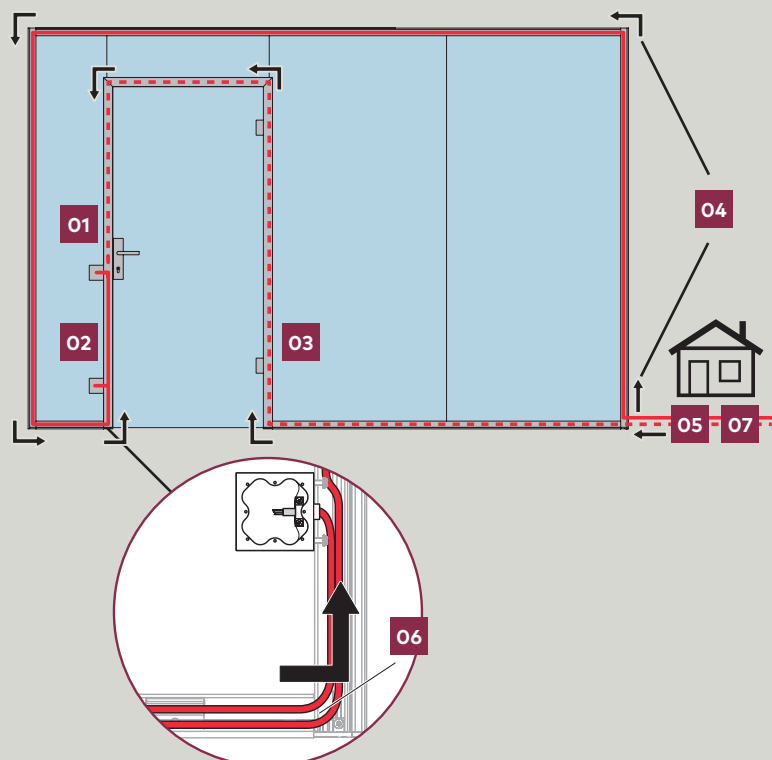



# NEW Lock versions

Now also possible with components from other manufacturers

UNIQUIN enables a diverse and varied lock portfolio, which can be individually designed with different lock functionalities, roses, lever handles or door plates.

**Note:** In addition to the rose, door plate and lever handle variants listed here, UNIQUIN locks can also be combined with components from other manufacturers.

## Example lock structure

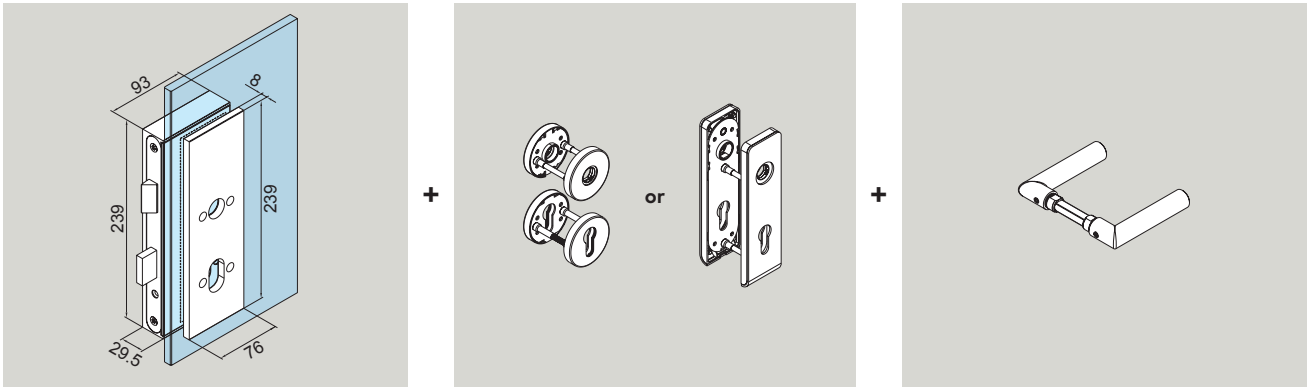

**Note:** The locks shown here are examples to show the possible lock variants. With a UNIQUIN order, these must be specified but not ordered separately, as a lock is always part of the standard equipment of a frame.

## Lock versions

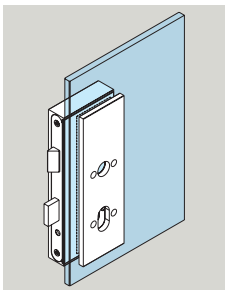

**Profile cylinder lock with whisper latch**  
prepared for lever handles with roses and PZ roses

same, but as unlockable lock (not shown)

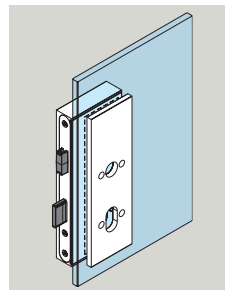

**Profile cylinder lock with magnetic latch**  
prepared for lever handles with roses and profile cylinder roses

same, but as unlockable lock (not shown)

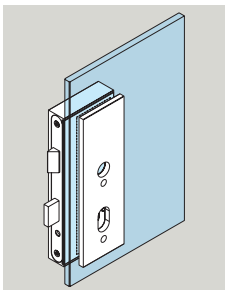

**Profile cylinder lock with whisper latch**  
prepared for short backplate

same, but as unlockable lock (not shown)

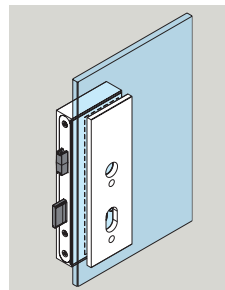

**Profile cylinder lock with magnetic latch**  
prepared for short backplate

same, but as unlockable lock (not shown)

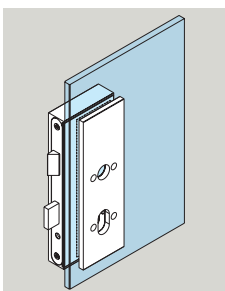

**Anti-panic lock according to DIN 179**  
prepared for lever handle with rose (always incl. lever handle / knob combination)

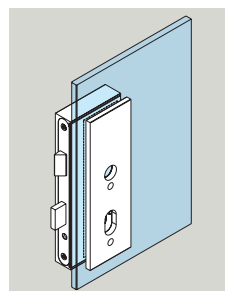

**Anti-panic lock according to DIN 179**  
prepared for short backplate (always incl. handle / knob combination)

**Anti-panic lock according to DIN 1125**  
(always incl. handle bar)

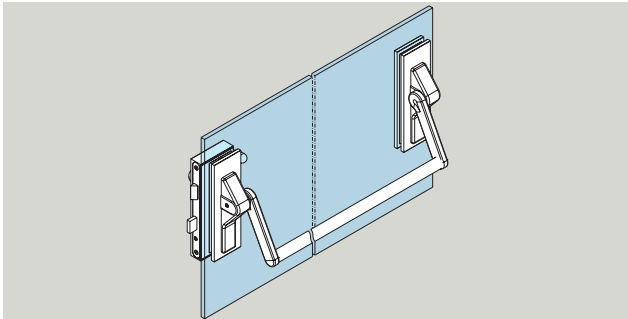

**Panic functions according to DIN EN 179 / 1125**

There is a lever handle / push bar or push bar on the inside. In the event of panic, exit is possible at any time, even when the door is closed.

**Panic function E (alternating function)**

There is a fixed knob on the outside. Access is only possible with a key.

**Panic function D (fire brigade function)**

There is a lever handle on the outside. The lever handle is in the idle function by using a split square pin on the outside until the lever handle on the inside (panic case) is operated. The handle on the outside remains coupled until the key is used to lock the door again and thus uncouple the handle. Access from the outside is possible either with a key or after a panic event due to the coupled lever handle.

**Panic function B (toggle function)**

There is a lever handle on the outside. The lever handle is always idle due to the use of a split square pin. The change-over function is activated by turning the key in the opposite closing direction. In the change-over function, the lock can be operated from both sides. Locking the lock with a key deactivates the handle on the outside again.

**UNIQUIN 2.0 Lock 2023**

Distance	72
Backset	55
Flat forend	
Width	20
Length	235
Thickness	3

**Lock variants**

- Whisper latch incl. adjustable striking plate
- Magnetic latch lock incl. strike plate

**Fitting combinations**

Round rose	UV	PZ
Diameter	55	
Fixing Drilling distance	38	
Installation height	8	
Fixing Screw	M5 countersunk head	

Square short plate	UV	PZ
Total length	170	
Width	45	
Distance	72	
Fixing Drilling distance	21.5	90.5
Fixing Screw	M5 countersunk head	

**Handle variants**

L form	Al	stainless steel
U form	Al	stainless steel
Fixed knob	Al	stainless steel
Turnable knob	Al	stainless steel

**Combination with access control**

- c-lever compact
- c-lever Air

The pre-prepared locks can be ordered for standard access control. Please take into account the values given above for drilling distance and type of fastening.

**Lever handles with roses**

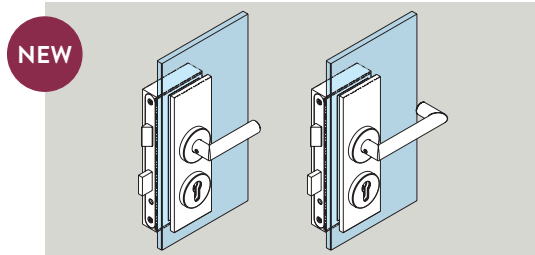

Lever handles with roses,  
L-shaped lever handles,  
U-shaped lever handles,  
cylinder lock roses

**Handle with short backplate**

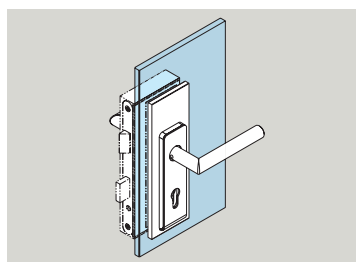

**Handle and knob**

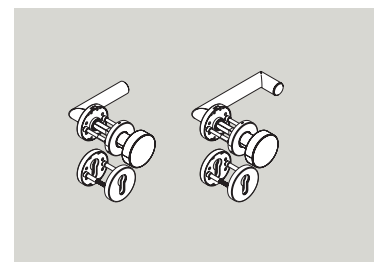

L-shaped lever handle,  
U-shaped lever handle,  
cylinder lock roses

# NEW Components for access control

Now also possible with components from other manufacturers

## Regulated access

(e.g. with the c-lever compact or **c-lever air from dormakaba**)

After a valid access medium has been provided, the digital light unit of the c-lever compact lights up and the door can be operated with the lever barrier-free. Optional access media: Card, key fob, key with RFID or smartphone.

Due to the standard-compliant lock design, the installation of access control systems from other manufacturers is possible without any problems in most cases. If you have any questions, please do not hesitate to contact our field service or application technology staff.

## c-lever compact

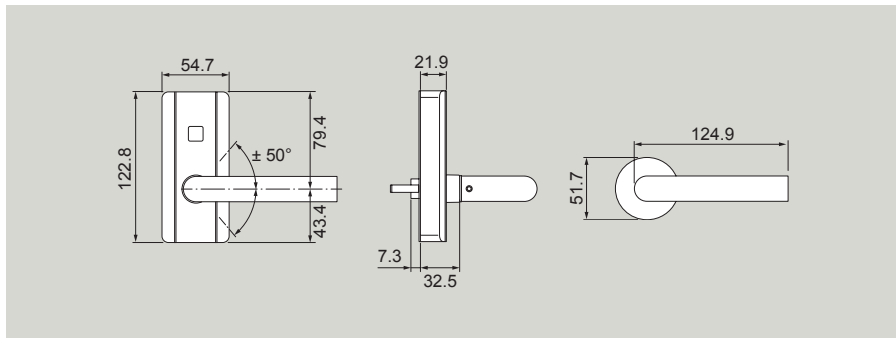

c-lever compact, standard version type 2725  
54.7 x 122.8 x 21.9 mm (B x H x T)

It is also possible to use the dormakaba c-lever air or other access control systems. The basis is always the UNIQUIN PZ lock, prepared for lever handles with roses and cylinder lock roses.

## Electric strike

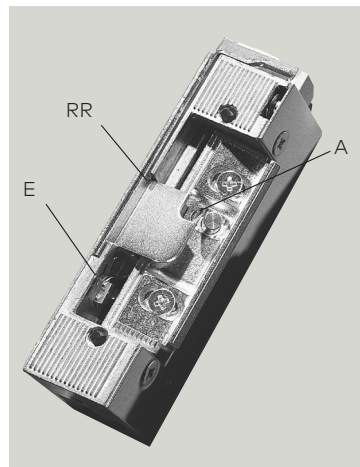
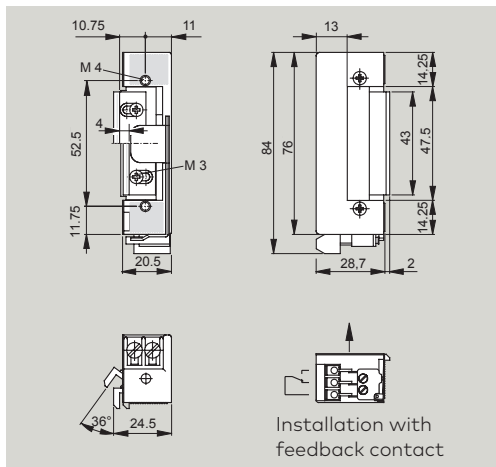

### A = Locking

If the strike lever is actuated briefly, the mechanism is unlocked in the strike and remains unlocked until the door is opened. Single entry possible.

### E = Unlocking

A small lever switches off the function of the electric strike. The door can be freely accessed without contact of the strike.

### RR = Feedback

A potential-free contact provides the information "door open / door closed".

### Data and features

	Basic	Basic-Safe
Electric strike series		
General doors	●	●
Symmetrical housing	●	●
German Industrial Standards (DIN) L and R applicable	●	●
Operating current version	●	-
Unlocking function (E)	●	-
Locking function (A)	●	-
Feedback contact (RR)	●	●

● = yes - = no

Electric strike with adjustable latch, for folding and non-rebated doors, DIN-L and DIN-R applicable.

Electric strike	Voltage	Current	Resistance	Type	Art. No.
Basic, Basic-R, Smoke	6 V AC	0.65 A	6.5 Ω	AE	15117406
	6 V DC	0.80 A			
	12 V AC	1.35 A			
	12 V DC	1.53 A			
Basic	12 V DC				15117112
Basic-Safe	12 V DC				15137112
	100% ED				
	100% ED				

# Information on europrofile cylinders provided by the customer depending on glass thickness

The required lengths of the europrofile cylinders (DIN 18252/EN 1303) for mortise locks depend on the corresponding glass thickness

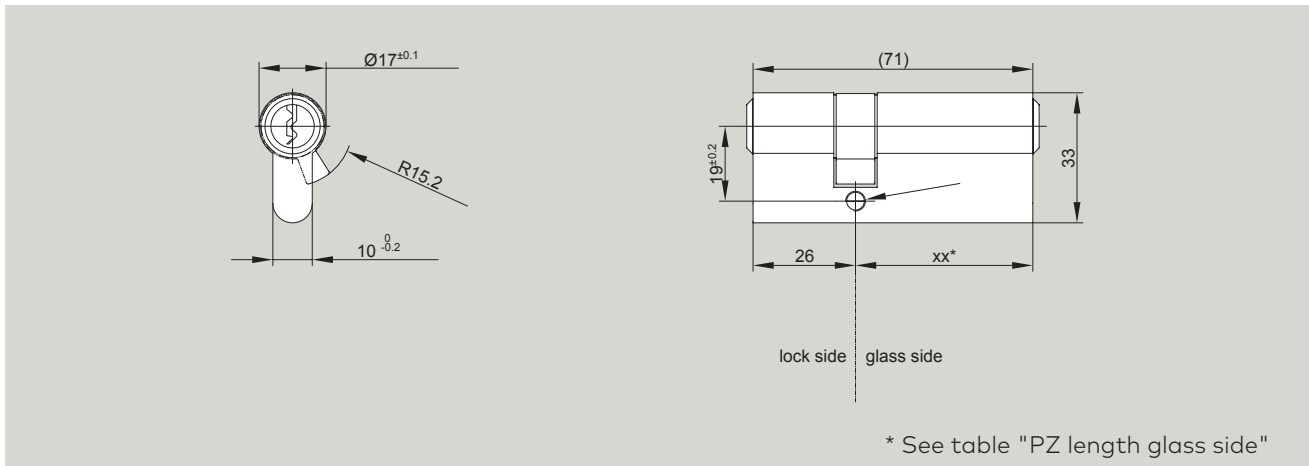

Glass thickness: 10 mm

Glass thickness	PZ length lock side	PZ length glass side
10	26	45
10.76	26	45
11.52	26	45
12	26	45
12.76	26	45
13.52	26	50
15	26	50
16.76	26	50
17.52	26	50
19	26	55

## Other accessories

### Product description

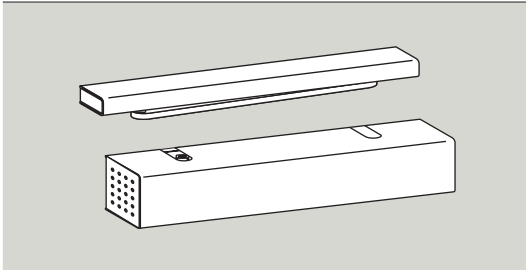

#### dormakaba TS 97 Cam-action door closer

- Barrier-free according to DIN 18040 for door widths up to 1100 mm
- Uniform length of door closer and slide channel
- Height 49 mm
- Easy door opening according to German Industrial Standard (DIN) SPEC 1104
- Low depth
- Adjustable closing force EN 2 – 4
- Includes standard limit stay

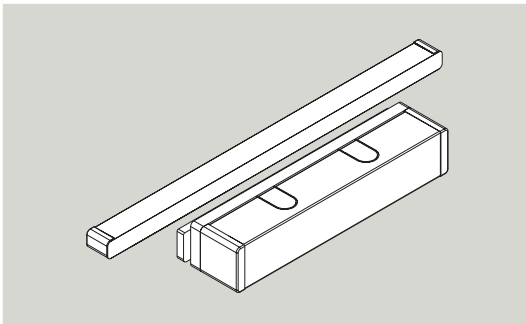

#### dormakaba TS 98 slide rail door closer

- Barrier-free in accordance with DIN 18040 for door widths up to 1400 mm
- Easy door opening according to DIN SPEC 1104; CEN / TR 15894
- Opening damping and closing delay as standard
- Almost noiseless closing
- Three different closing ranges 180° – 15°; 15° – 0°; 7° – 0°
- Including opening limiter as standard
- Easy adjustment of use due to hydraulic functions (closing force EN 1 – 6)
- Adjustment of all functions always from the front

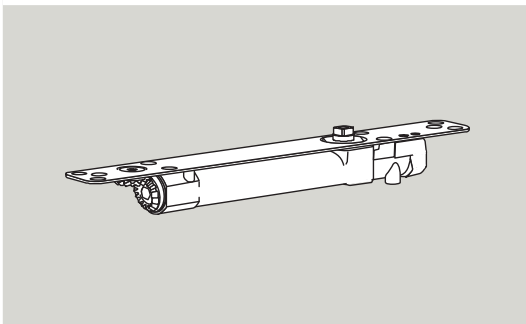

#### Concealed dormakaba ITS 96 slide channel door closer system for use in timber doors

- Extensive range of models for barrier-free building
- Easy door opening according to German Industrial Standard (DIN) SPEC 1104
- EASY OPEN technology
- Adjustable closing force and closing time
- For door leaf widths up to 1100 mm
- Length: 277 mm, depth 32 mm, height 42 mm
- Latching action can be switched on or off
- Continuously adjustable closing force EN 2 – 4 (EN 3 – 6)
- Max. leaf width ≤ 1100 mm (≤ 1400 mm)
- Max. leaf weight ≤ 130 kg (≤ 180 kg)

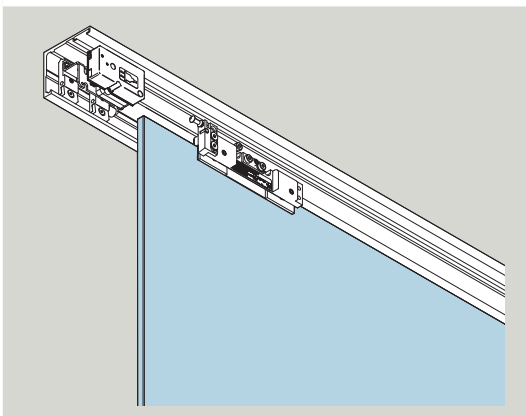



Integrated locking device and status indicator

Integrated locking device (only in connection with DORMOTION)

- Can be retrofitted (note profile system)
- Battery operated, alternatively also available as a transformer
- No safety lock
- No outdoor facilities

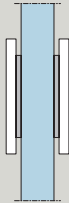
**Note:** Retrofitting of door closers is possible. Please note that this requires an additional replacement of the frame profiles.

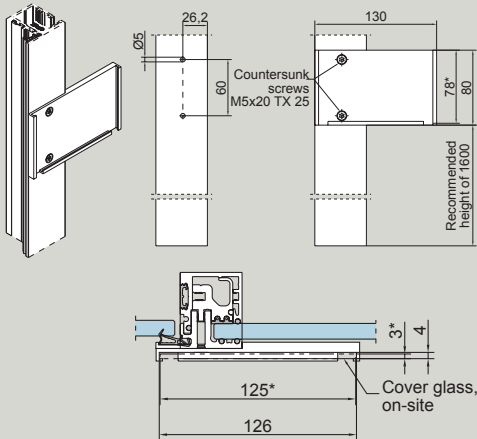
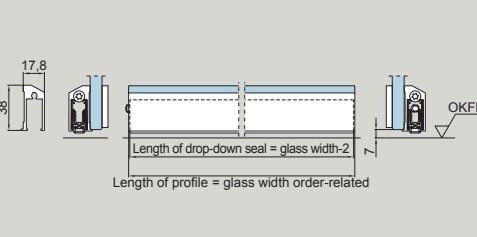
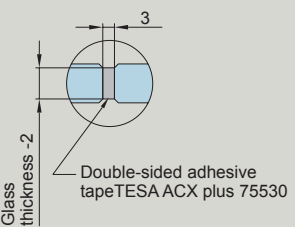
	Product description	DIN	Art. No.
	<p><b>NEW</b> <b>UNIQUIN glazing bar profile</b> (35 x 3 mm), for gluing on, incl. double-sided adhesive tape, fixed length up to max. 2.960 mm</p>		50.420
	<p><b>UNIQUIN touch-up stick</b> for surface / paint repairs recommended for the optical adjustment of laterally blank saw cuts</p>		50.835
	<p><b>NEW</b> <b>UNIQUIN door plate</b> Mounting on frame profile</p>	right left	50.525 50.526
<p>Recommended dimensions (*) for cover glass are shown in the drawing.</p>			
	<p><b>UNIQUIN drop-down seal</b> complete incl. counter plate for release pin</p>		
<p>Length 835 – 710 mm (can be shortened on site) 50.831                  Length 960 – 835 mm (can be shortened on site) 50.832                  Length 1085 – 960 mm (can be shortened on site) 50.833                  Length 1210 – 1085 mm (can be shortened on site) 50.834                  other lengths on request</p>			
<p>UNIQUIN drop-down seals can also be retrofitted.</p>			
	<p><b>NEW</b> <b>Double-sided adhesive tape (TESA ACX Plus)</b> for filling the glass gaps between glass elements and for simultaneous bonding of the glass elements</p> <p>for 10 – 10.76 mm glass thickness, 12 m roll, 8 x 3 mm 50.529                  for 12 – 12.76 mm glass thickness, 12 m roll, 10 x 3 mm 50.530                  for 13 – 13.52 mm glass thickness, 12 m roll, 11 x 3 mm 50.531                  for 15 mm glass thickness, 12 m roll, 13 x 3 mm 50.532                  for 17 mm glass thickness, 12 m roll, 15 x 3 mm 50.533                  for 19 mm glass thickness, 12 m roll, 17 x 3 mm 50.534</p>		

# Single-action door glass preparation

**Attention:** The hinge glass preparations shown here are only relevant for the UNIQUIN hinges 2023 Standard. For the UNIQUIN hinge Clamp&Cover 80 no hinge preparation is necessary.

**For locks and hinges up to frame height 2200 mm**

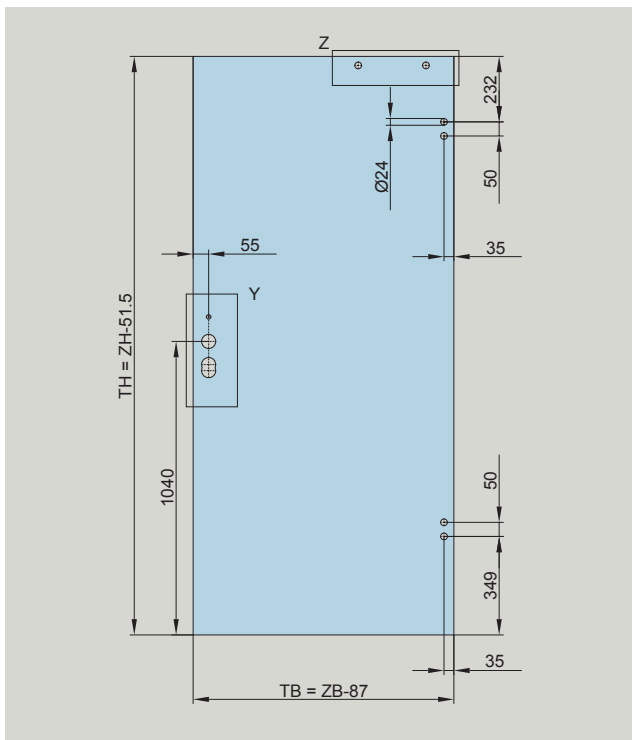

**For locks and hinges up to frame height of 2201 mm to 3000 mm**

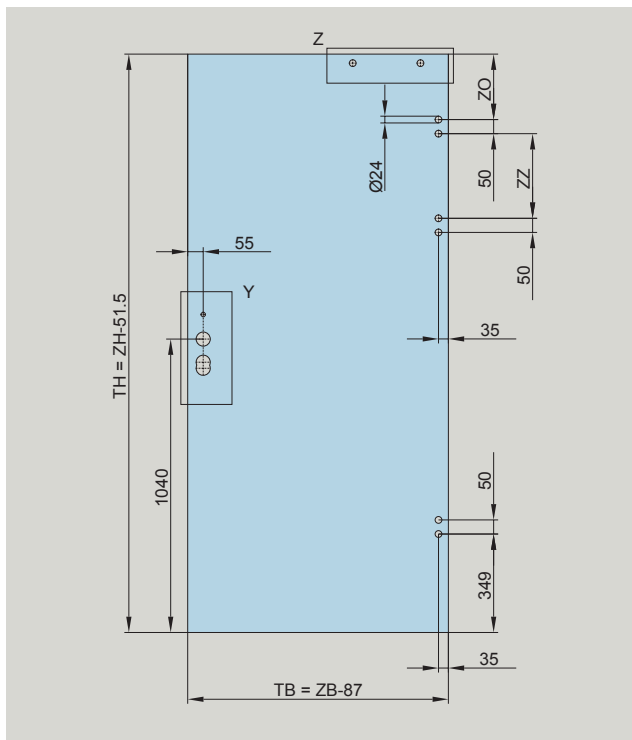

**Detail Y**  
Preparation for lock

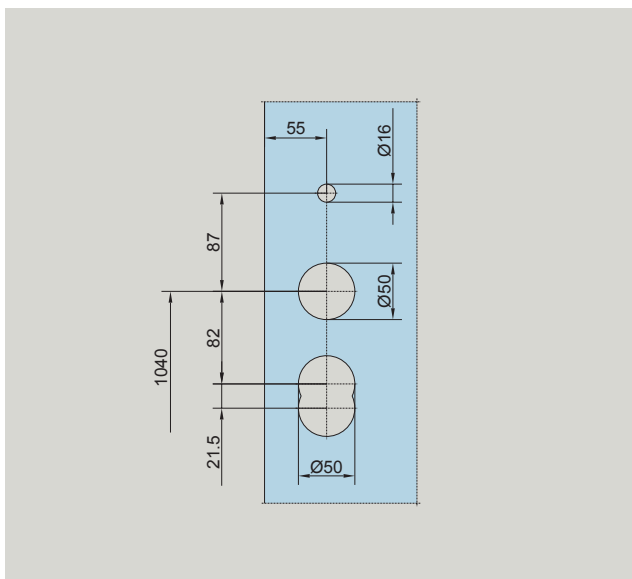

**Detail Z**  
Preparation TS 97

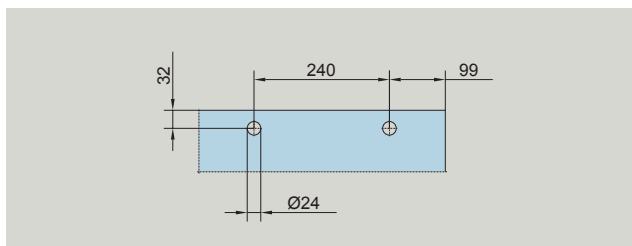

**Detail Z**  
Preparation TS 98

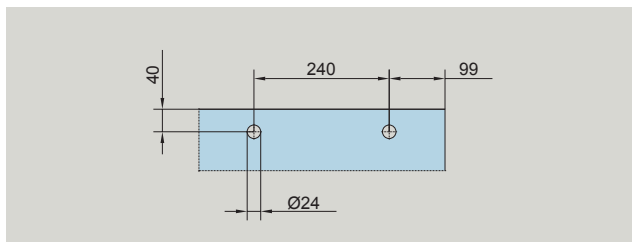

TB = Door width  
TH = Door height  
ZB = Frame width  
ZH = Frame height

Frame height	Glass preparation hinge	
mm	ZO (mm)	ZZ (mm)
2201-2600	232	250
2601-3000	313	331



# Glass preparation: single-action door with panic function with pushbar

**Attention:** The hinge glass preparations shown here are for panic door lock with handle bar and hinges. Detail Z is only required for TS insert.

For locks and hinges up to frame height 2200 mm

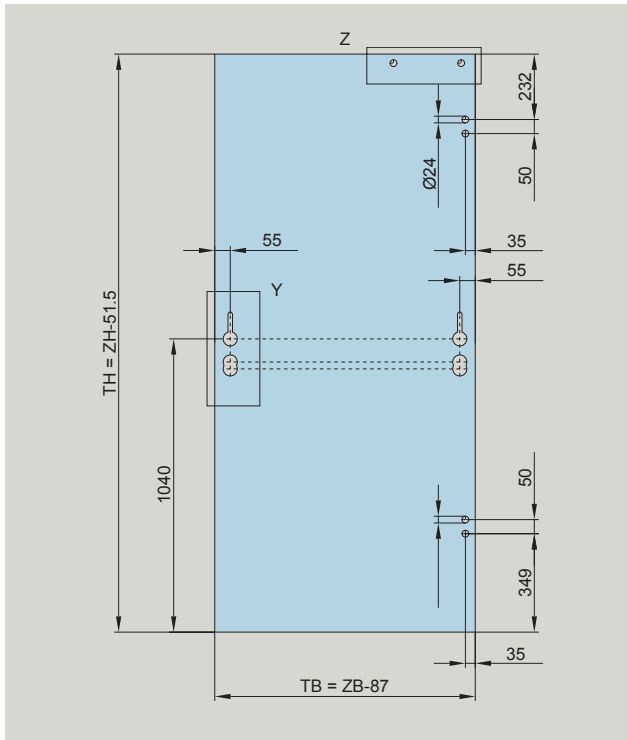

For locks and hinges up to frame height of ab 2201 mm

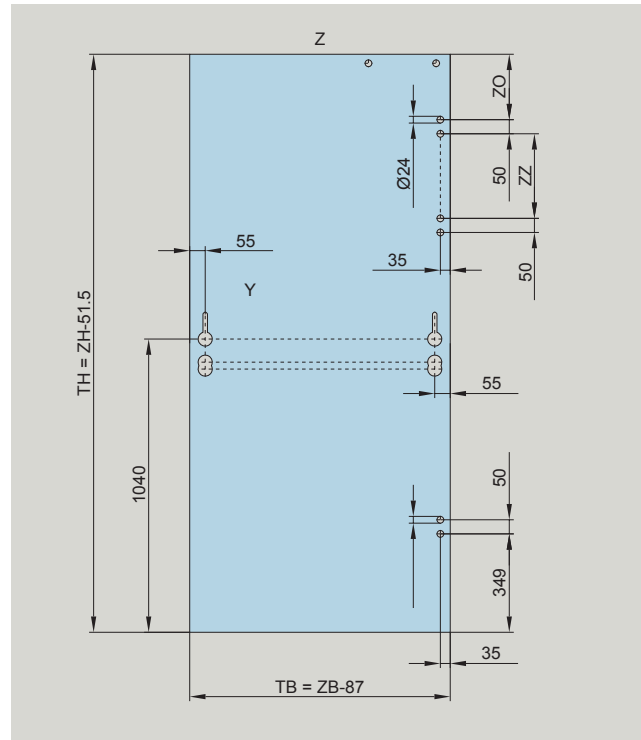

## Detail Y

Preparation for lock

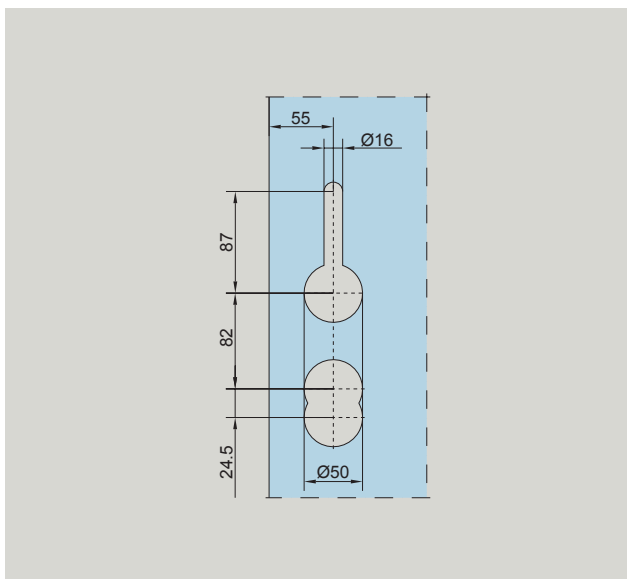

## Detail Z

Preparation TS 97

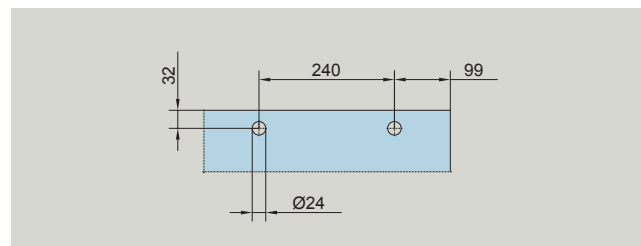

## Detail Z

Preparation TS 98

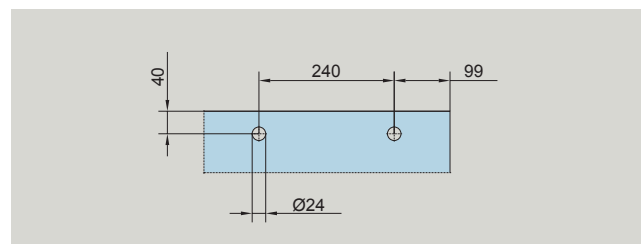

TB = Door width  
 TH = Door height  
 ZB = Frame width  
 ZH = Frame height

Frame height mm	Glass preparation hinge	
	ZO (mm)	ZZ (mm)
2201-2600	232	250
2601-3000	313	331

# Glass preparation: sliding door MUTO Comfort L 80

## single-leaf

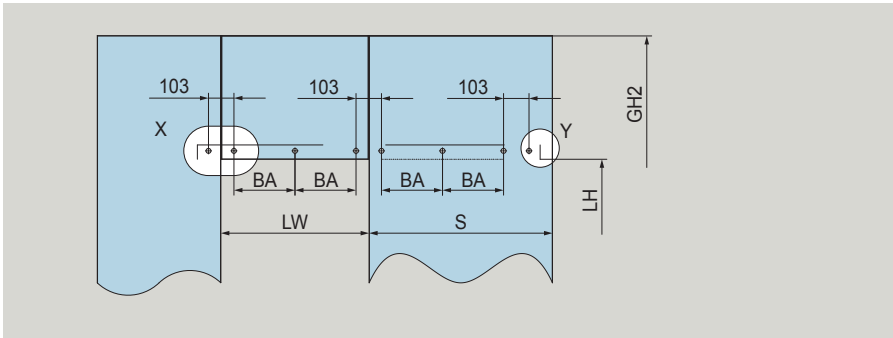

$$A = LW + 60$$

$$B = 2 \times A + 67$$

$$BA^* = 2 \times (LW - 106) / T$$

	T	AB
$600 \leq LW \leq 800$	4	8
$801 \leq LW \leq 1000$	6	10
$1001 \leq LW \leq 1200$	8	12
$1201 \leq LW \leq 1500$	10	14
$1501 \leq LW \leq 2000$	12	16

## double-leaf

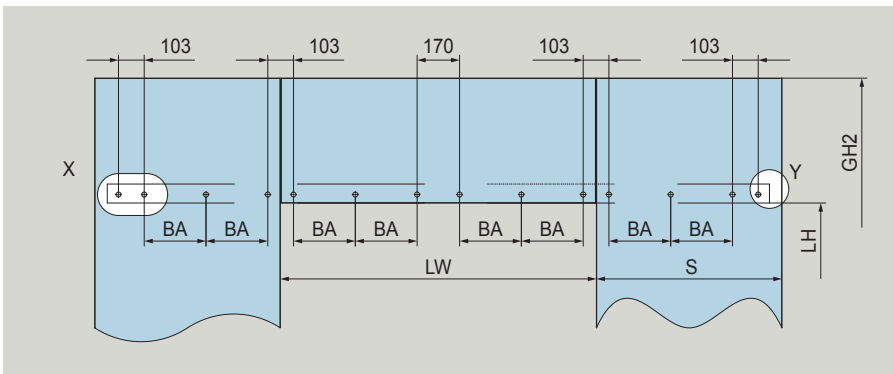

$$A = LW/2 + 27$$

$$B = 4 \times A + 12$$

$$BA^* = 2 \times (LW - 106 - 170) / T$$

	T	AB
$1200 \leq LW \leq 1500$	8	14
$1501 \leq LW \leq 2000$	12	18
$2001 \leq LW \leq 2900$	16	22

## Details

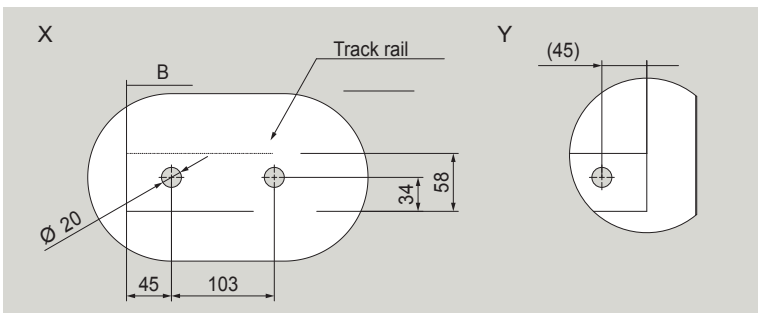

## Pull handle

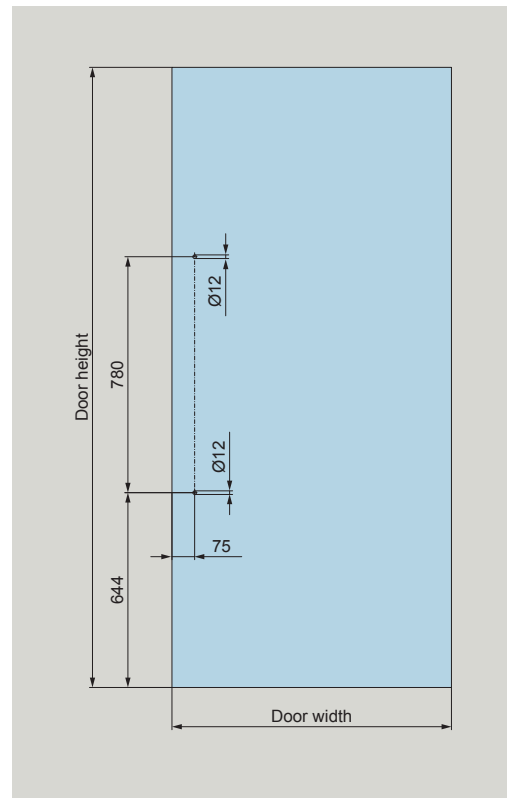

- A = Leaf width
- AB = Number of holes
- B = Track rail length
- BA = Hole distance
- GH2 = Sidelight glass height
- LH = Clear height
- LW = Clear passage width
- S = Sidelight glass width
- T = Number of divisions (BA\*)

# Space for your notes



# Timber preparation

The thickness of the timber door depends on the thickness of the fixed glazing, see "The Detail" 50-032A

## For BaSys hinge

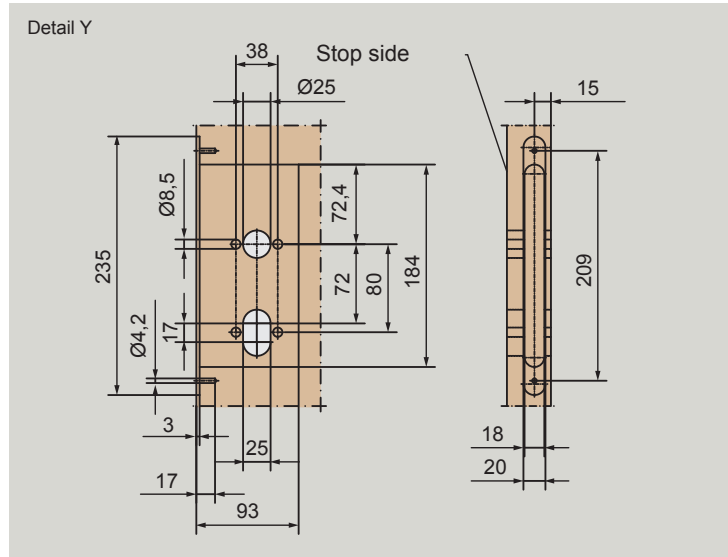
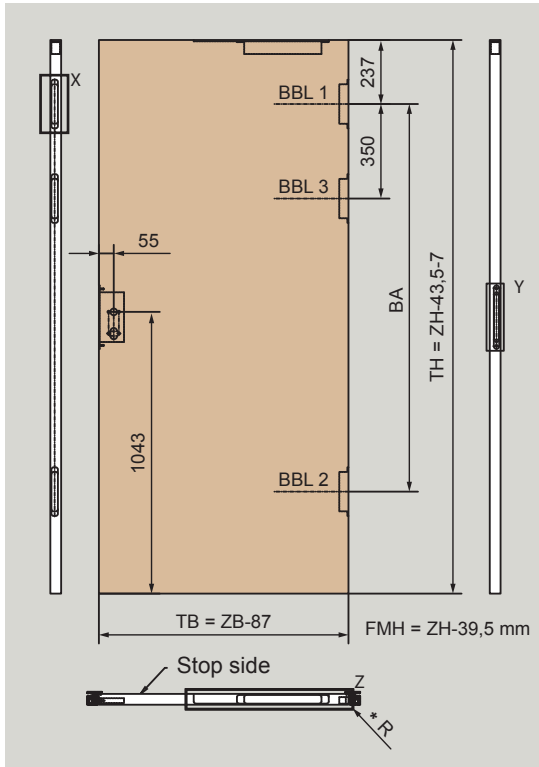

**Note:** The timber door leaf must be prepared for a mortise lock in accordance with DIN 18251.

Lock specification

Backset: 55 mm; distance: 72 mm; forend width: 20 mm; forend length: 235 mm

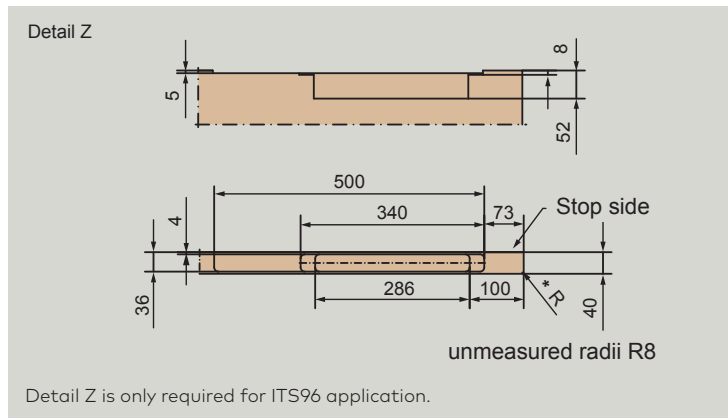
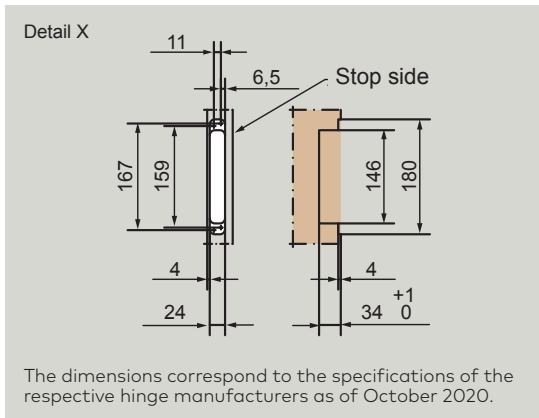

## BaSys hinge PIVOTA DX 100 3-D

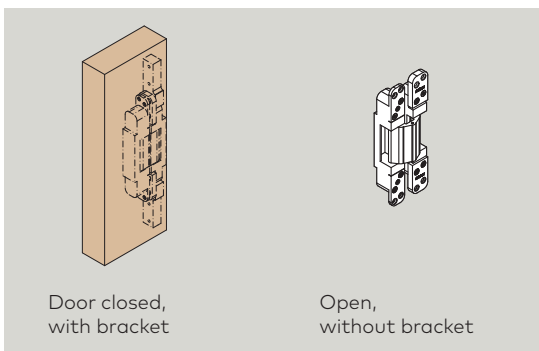

Hinge distance in accordance with DIN 18101

FMH (mm)	BA (mm)
1796 – 1920	1310
1921 – 2045	1435
2046 – 2170	1435
2171 – 2295	1685
2296 – 2420	1810
2421 – 2545	1935
2546 – 2670	2060
2671 – 2795	2185
*2796 – 2920	2310
*2921 – 2965	2435

- TB = Door width
- TH = Door height
- ZB = Frame width
- ZH = Frame height
- BBL = Hinge datum line
- FMH = Frame rebate height
- FMB = Frame rebate width
- BA = Hinge distance

\* Custom size

# Technical Support

The widths of the frame, glass and access point are dependent on each other.

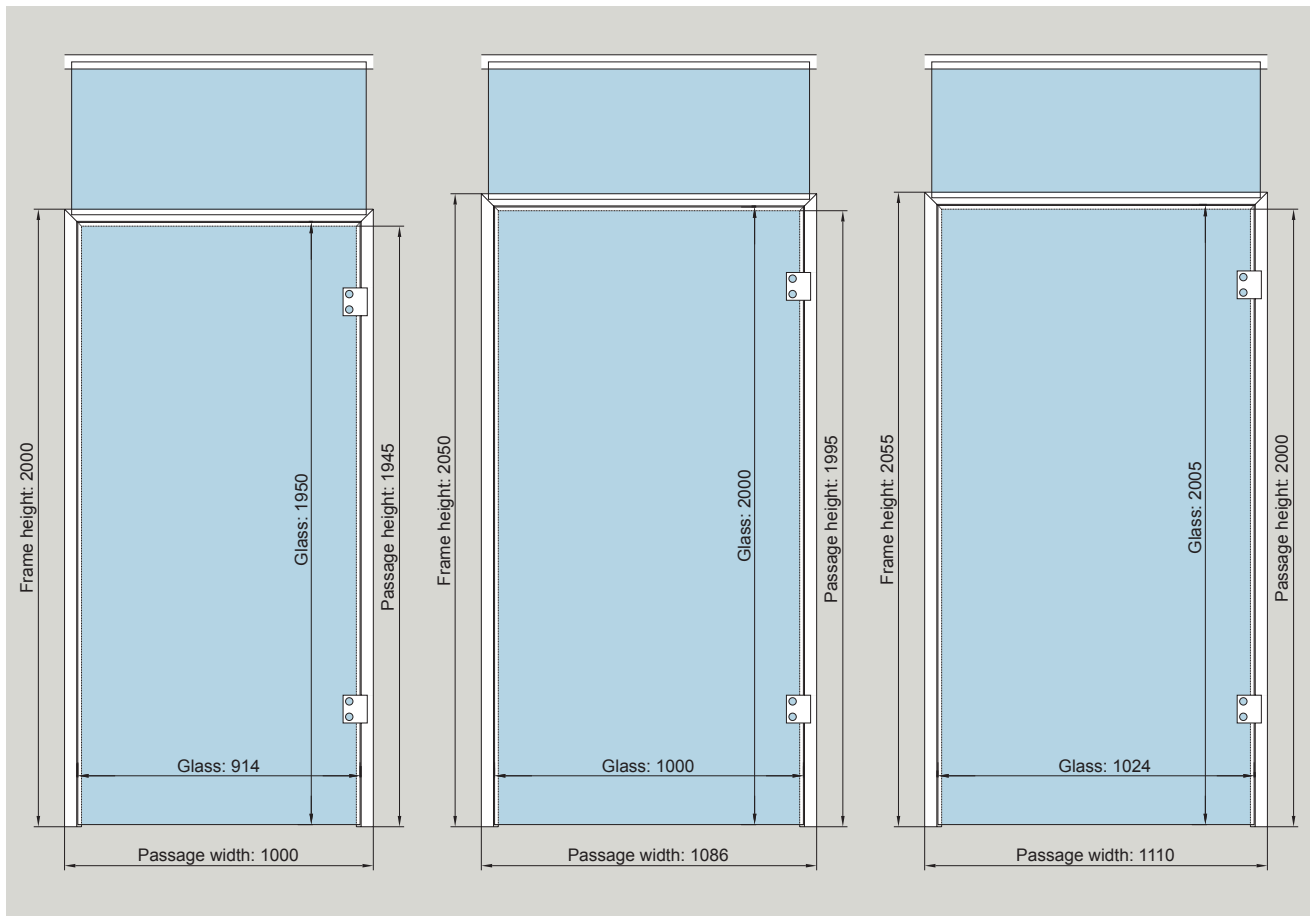

Do you need support with creating your individual drawings? Please contact our application technology department. They will be happy to send you detailed drawings as templates or to advise you personally, for example when planning sloping roofs, for which individual profiles can be ordered that must then be adapted by the customer.

You can also benefit from our customer training programs. The First Glass Experience training event is an exclusive series of training courses on our DORMA-Glas glass systems (IGS), consisting of three modules that build on each other.

**Note:** An inquiry form for downloading can be found at [www.dorma-glas.com](http://www.dorma-glas.com) under the product category "UNIQUIN".

# Installation instructions

We plan systems in accordance with the generally valid requirements of the glass industry. Glass is calculated on the aspect ratio of 1:10.

Please note that in the case of uneven systems (e.g. due to construction tolerances), we always use the largest measurement. If necessary, the profiles must be adapted and/or underpinned on site or ordered with extra length for adaptation by the customer.

The fastening material is not supplied and must be provided on site to suit the building surface.

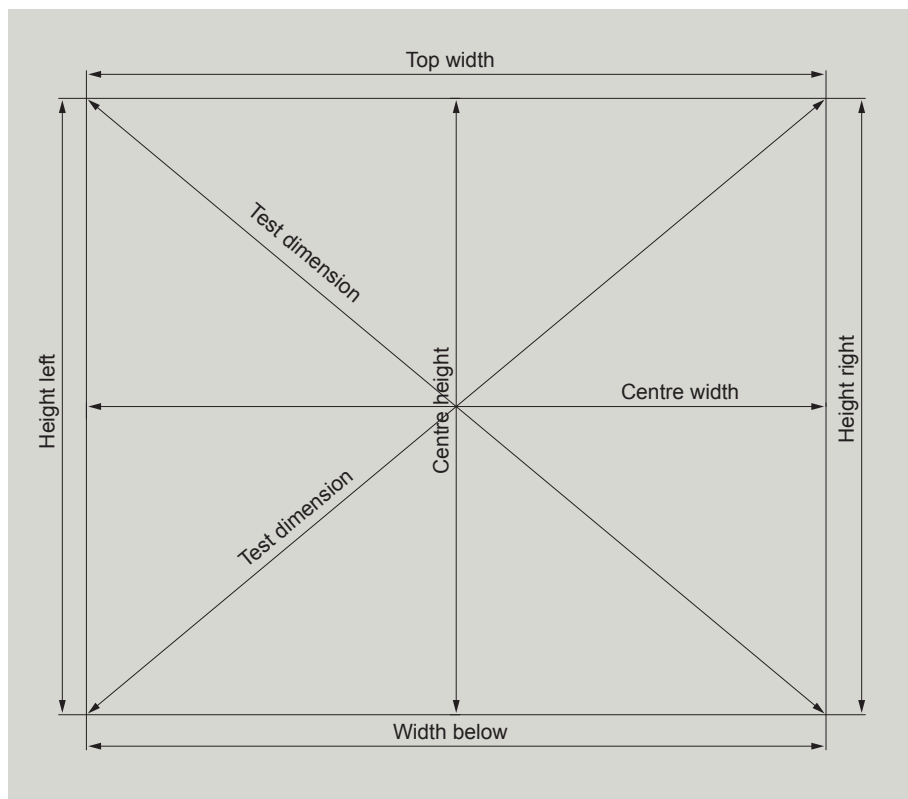

## Measure correctly

We recommend determining the dimensions according to the following criteria (see also Tips and tricks):

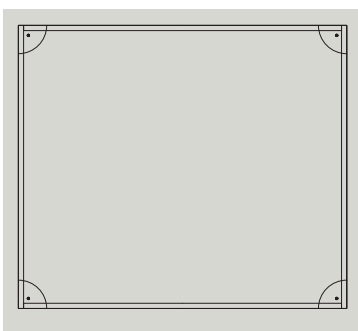

### Ideal allowances

System in fixed or extra length 20 mm or individual extra length

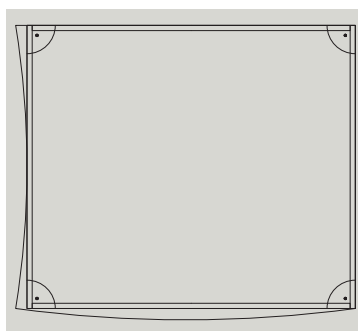

### Uneven walls

Extra length 20 mm or individual extra length

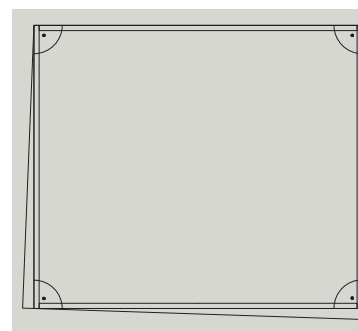

### Inclined walls

Extra length 20 mm or individual extra length



# Tips and tricks

## Planning specifics

### System planning

Generally, systems are planned with frame dimensions of 1010 x 2155 mm (W x H), provided that no individual frame dimensions have been specified by the customer. Thus, an accessible passage of 900 x 2100 mm (W x H) is ensured. In order to avoid collisions between door closer and the wall when opening the door, the use of a sidelight with a width of min. 1/10th of the system height is recommended on the frame side of the hinge suspension. A design with overpanel and sidelight simplifies the installation and supports the compact design of the system. Release drawings show the view from the inside\*.

### Sloping walls / ceiling / floor

Please note that DORMA-Glas cannot provide recommendations or empirical data for vents in the respective surfaces. Please provide us with a measurement that includes the required air in order to be able to compensate for tolerances.

### Systems with sliding doors

UNIQUIN sliding doors are always installed on the outside of the system. In the case of narrow systems with sliding doors, it may happen that the configured standard track rail is too long. **Tip:** Order the sliding door system with the clear passage width pre-bored accordingly. The rail can then be shortened on site.

### Angles

UNIQUIN can be implemented as a segmented system configuration for room corners between 90° and 180° (standard angle 90°), whereby the mitre cuts are made by the customer. In direct connection to a frame, a sliding door and/or an acoustic element, a fixed panel must be planned and installed aligned on both sides.

### Curved system configuration

On request, a curved system profile (no circular arcs!) can also be implemented. In this case, longer delivery times may be expected.

### Measurement

If no upstream work has been done, it is advisable to determine the glass for solid elements as well as glass and frames for room-height doors only after assembly of the complete system.

### Frame in masonry with door closer:

If a door closer is installed in a frame in masonry, the frame must be flush with the wall, otherwise the door closer will strike the masonry and the opening of the door will be severely limited (see sketch on page 42 for opening angle).

### Beam, corner cut-out:

Profiles must be cut to mitre on site (see sketch).

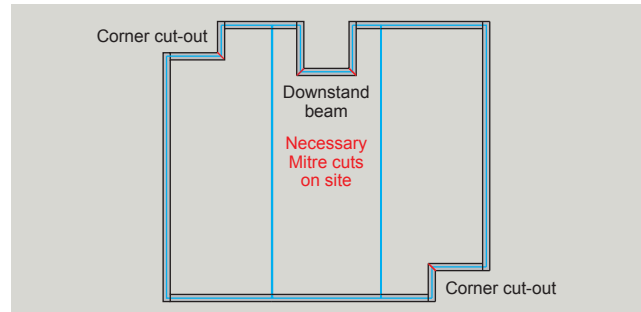

### Order details

Please include a suitable sketch with all relevant dimensions in your inquiry / order. Release drawings show the view from the inside\*. They are initially free of charge.

Costs are only charged from the second change. In order to avoid this, we provide you with a checklist for reviewing all necessary UNIQUIN order details.



### Delivery length of the mounting frames

Mounting frames (46/55) can be ordered custom-fitted (in fixed dimensions) or with an extra length of 20 mm (e.g. in the case of slanted ceilings or walls) free of charge. Individual overlengths, on the other hand, are charged.

### Accessories from other manufacturers

On request, the system can be planned with a technical sealing tape from tesa (3 mm gap).



\*Inside = cover profile side for fixed elements / hinge side for single-action doors / back side for sliding doors.

# Safety-related information

## Important safety-related information for the mounting and use of DORMA-Glas glass fittings.

(Follow these instructions in addition to the mounting and operating instructions in order to avoid damage of product and damage to person or property.)

**Important:** All users have to be informed about relevant points mentioned in these safety-related information and the mounting and operating instructions!

### General information

1. DORMA-Glas recommends the use of TSG-H (heat-stored tempered safety glass) according to DIN EN 12150-1.
2. DORMA-Glas glass fittings are not suitable for outdoor installation.
3. DORMA-Glas glass fittings are not suitable for rooms where chemicals (e.g. chlorine) are used, e.g. swimming pools, saunas and brine baths.



4. Sliding panels must not be moved faster than walking speed and must be stopped manually before reaching the end position.
5. Pivoting panels must not be thrown too hard. If there is a risk of over-turning, this must be prevented by a door stop.

### Mounting

1. Only properly qualified and specially trained staff is authorised to mount DORMA-Glas glass fittings.
2. Never use glass with conchoidal fractures and/or damaged edges.
3. Due to crushing hazards – among others in the area of the secondary closing edge – and possible injury caused by breakage of glass during mounting, corresponding protective clothing (especially gloves and protective goggles) is required.
4. Clean clamping area with fat solvent (standard commercial cleaning agent) before mounting the glass fitting.
5. Never use clamping shoes on structured glass surfaces (except on satined glass) or glass of heavily varying thickness unless with a corresponding levelling layer.
6. Never use clamping shoes on self-cleaning coatings.
7. When adjusting glass elements, always stick to the required clearance for the respective fitting. Adjust clearance so that the glass does not touch hard components such as glass, metal or concrete.
8. Make sure not to use excessive force when installing the glass (avoid local stress resulting from very tight screws).

### Maintenance

Check fittings at regular intervals for proper positioning and smooth running and door for correct adjustment. Especially highly-frequented door systems require inspection by properly qualified staff (specialised companies or installation firms). Immediately replace damaged glass elements (no glass flaking and/or conchoidal fractures)!

### General care instructions

The surface finishes of the fittings are not maintenance-free and should be cleaned according to their material and design.

- For metallic surfaces (anodised finishes, stainless steel) please use appropriate cleaning agents without abrasive additives only.
- For varnished surfaces please use appropriate solvent-free cleaning agents only.
- Brass surfaces (without surface protection) have to be treated with an appropriate maintenance agent on occasion, to avoid tarnishing.

**For practical planning, please use our drawings DORMA-Glas "The Detail".**

The printed colours indicating the surface finishes are not 100 % true, but do provide a useful guide. Statements made with regard to the nature or use of the products are for the purposes of descriptions. Assent with regard to the existence of particular properties or particular uses always requires special written agreement. Pictures may show special designs which are different to the standard scope of delivery.

Subject to change without notice.

# Moving Details.



**DORMA-Glas GmbH**

Max-Planck-Straße 33-45  
D - 32107 Bad Salzuflen

T +49 5222 924-0

[info@dorma-glas.com](mailto:info@dorma-glas.com)  
[www.dorma-glas.com](http://www.dorma-glas.com)

 DORMA-Glas GmbH  
 DORMA-Glas GmbH



WN 05523651532, 01/24, EN  
Subject to technical modifications